



LABORATORY MANUAL FOR

---

# ANALOG COMMUNICATIONS

---

LAB V (EE4330)

كلية الهندسة

*Prepared by*

Dr. Mohammed Ali AlMahamdy

&

Abdullah Kh. Ahmed

2004

Using modules and manuals of K&H MFG Co., LTD.

## TABLE OF CONTENTS

TABLE OF CONTENTS .....	2
RF OSCILLATOR.....	3
SECOND ORDER FILTER.....	10
AM MODULATORS .....	20
AM DEMODULATORS.....	28
VCO & FM MODULATORS .....	37
FREQUENCY DIVISION MULTIPLEXING.....	46
SPECTRUM OF SIGNALS AND FILTERING .....	76
SIMULATION OF AM & FM .....	79

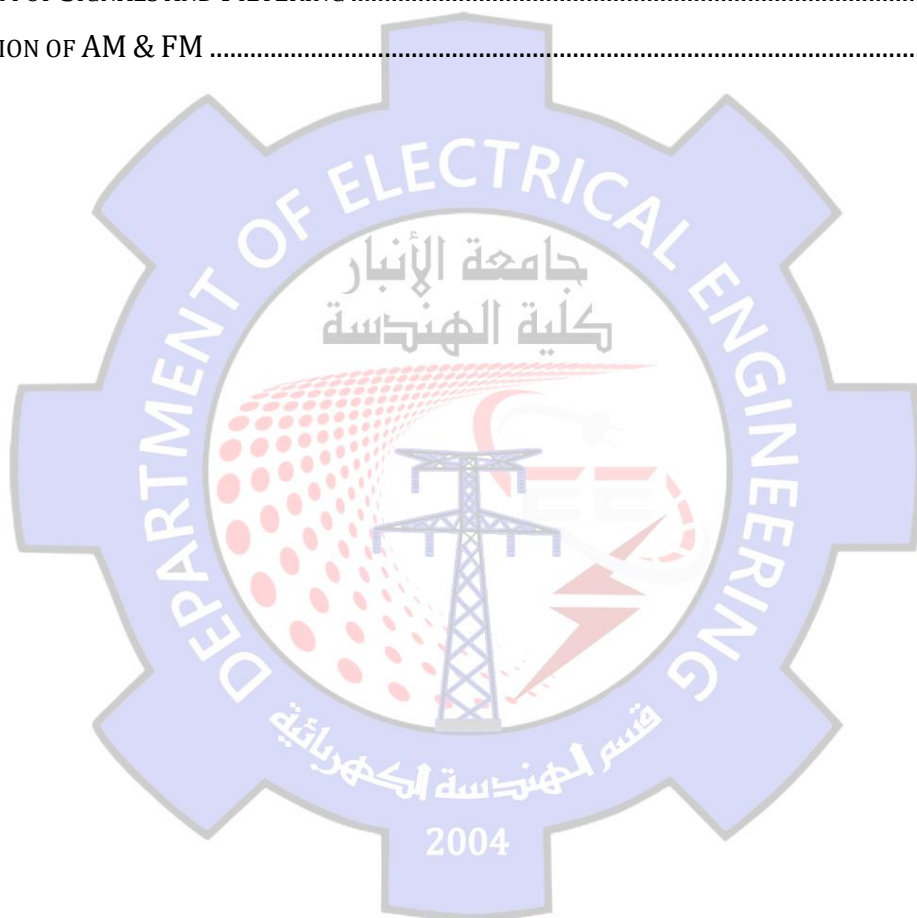

## RF OSCILLATOR

### 1. OBJECTIVES

In traditional communication system exhibits two

- (1) Understanding the operation and characteristics of radio-frequency (RF) oscillators.
- (2) Designing and implementing oscillators

### 2. DISCUSSION OF FUNDAMENTALS

An oscillator is simply a signal generator converting its dc supply voltage into a continuously repeating ac output signal without any input signal. Oscillators play very important roles in communication systems. An oscillator generates the carrier or local oscillation signal used in any communication system.

Fig.1-1 shows the basic block diagram of oscillator. It includes an amplifier and a feedback network constructed by the resonator. When dc power is first applied to the circuit, noise will appear in the circuit and is amplified by the amplifier and then fed to the input through the feedback network that is a resonant circuit with filter function. The feedback network permits the signal frequency equaling the resonant frequency to pass and rejects other frequencies. The feedback signal will be amplified and fed back again. If the feedback signal is in phase with the signal at input and voltage gain is enough, the oscillator will be operation.

For proper operation, an oscillator must meet Barkhausen criterion. Barkhausen criterion is the relationship between the amplifier's gain  $A$  and the oscillator's feedback factor  $\beta(s)$  and should be equal to 1. That is

$$A\beta(s) \geq 1 \quad (1-1)$$

Where

$A$  : amplifier's gain

$\beta(s)$  : oscillator's feedback factor

Transistor oscillators will be used in our experiments. A transistor amplifier with nonlinear  $i_c - V_{be}$  characteristic serves as an amplitude limiter. An oscillator with limiter function is also called a self-limiting oscillator when its loop gain equals 1. Therefore, such an oscillator circuit is no need to append other amplitude limiters.

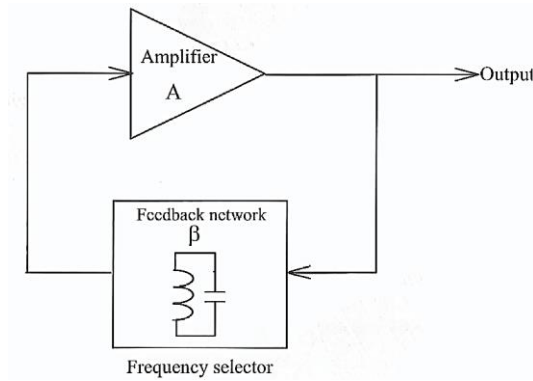

Fig.1-1 Basic block diagram of an oscillator

### Colpitts Oscillator

An ac equivalent circuit of Colpitts oscillator is shown in Fig. 1-2. Since the LC parallel-resonant circuit is connected between the base and the collector of transistor, partial feedback voltage is fed to the emitter through the voltage divider constituted by  $C_1$  and  $C_2$ . In this circuit, the  $R$  represents the sum of the output resistance of transistor, load resistance and the equivalent resistance of inductor and capacitor.

If the frequency is not very high, the internal capacitances of transistor can be neglected and the oscillating frequency of Colpitts oscillator can be calculated by the formula

$$f_0 = \frac{1}{2\pi \sqrt{L \left( \frac{C_1 C_2}{C_1 + C_2} \right)}} \quad (\text{Hz}) \quad (1-2)$$

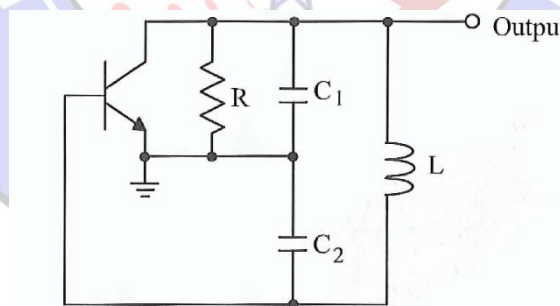

Fig.1-2 AC equivalent of Colpitts oscillator

In Colpitts oscillator circuit, the feedback factor  $\beta$  is  $C_1/C_2$  and the voltage gain  $A$  is  $g_m R$ .

By Eq. (1-1)  $A\beta(s) = 1$ , we obtain  $g_m R \frac{C_1}{C_2} = 1$ , or  $g_m R = \frac{C_2}{C_1}$

For starting oscillation, the loop gain should be at least 1 so that the oscillation condition can be expressed by

$$g_m R \geq \frac{C_2}{C_1} \quad (1-3)$$

Fig. 1-3 shows a practical Colpitts oscillator circuit. The resistors R1, R2, R3 and R4 determine the bias of transistor. C<sub>1</sub> is the coupling capacitor and C<sub>2</sub> is the bypass capacitor. The frequency of oscillation is determined by the values of C<sub>3</sub>, C<sub>4</sub> and L<sub>1</sub>.

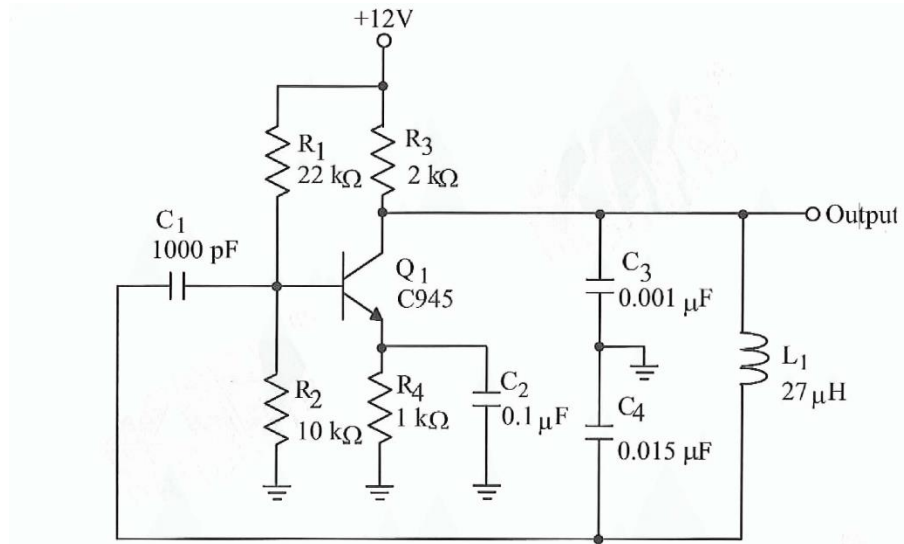

Fig.1-3 Colpitts oscillator circuit

### Hartley Oscillator

The ac equivalent circuit of Hartley oscillator, shown in Fig. 1-4, is similar to the Colpitts oscillator. The parallel LC resonant tank is connected between the collector and base, however, two inductors L<sub>1</sub> and L<sub>2</sub> are used instead of two capacitors. The R represents the sum of transistor's output resistance, load resistance and the equivalent resistance of inductors and capacitor.

If operating frequency is not very high, the stray capacitance of transistor can be neglected and the oscillating frequency is determined by the component values of parallel-resonant circuit and can be calculated by the formula

$$f_0 = \frac{1}{2\pi\sqrt{(L_1 + L_2)C}} \quad (\text{Hz}) \quad (1-4)$$

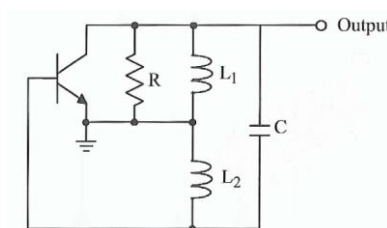

Fig.1-4 AC equivalent of Hartley oscillator

In Hartley oscillator circuit, the feedback factor  $\beta$  is  $L_2/L_1$  and the voltage gain  $A$  is  $g_m R$ .

By Eq. (1-1)  $A\beta(s) = 1$ , we obtain  $g_m R \frac{L_2}{L_1} = 1$  or  $g_m R = \frac{L_1}{L_2}$ .

For starting oscillation, the loop gain should be at least 1 so that the oscillation condition can be expressed by

$$g_m R \geq \frac{L_1}{L_2} \quad (1-5)$$

Fig. 1-5 shows a practical Hartley oscillator circuit. Resistors  $R_1$ ,  $R_2$  and  $R_3$  provide the bias for transistor.  $C_1$  is the couple capacitor and  $C_2$  is the bypass capacitor.  $C_3$ ,  $L_1$  and  $L_2$  form a resonant circuit for determining the operating frequency.

Excepting the oscillators mentioned above, there are many other types of oscillators in practical applications: such as RC phase-shift and Wein bridge oscillators for low frequency requirement, Clapp and Pierce oscillators for high stability. In general, Pierce oscillator is the most common use in high-frequency applications due to the use of crystal that has low power consumption and very high and stable Q.

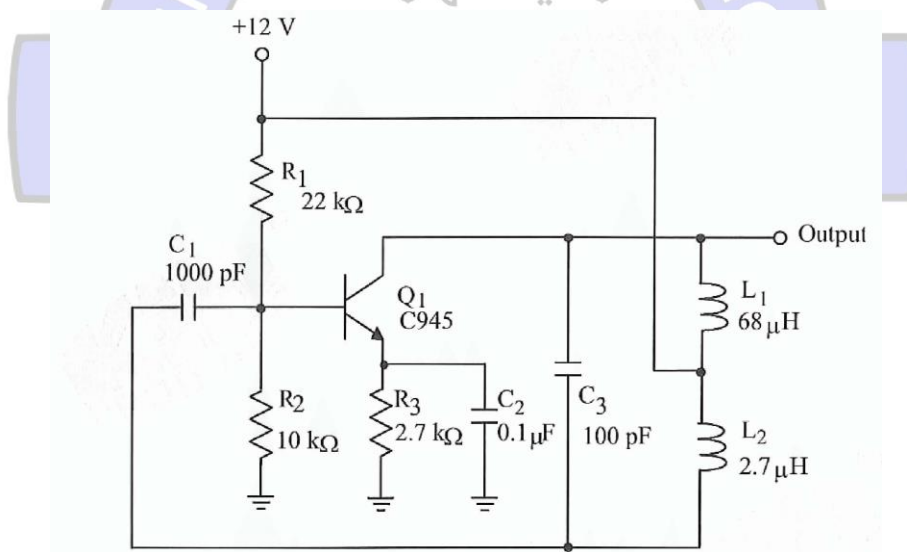

Fig.1-5 Hartley oscillator circuit

### 3. EQUIPMENT REQUIRED

- (1) Module KL-96001
- (2) Module KL-93001
- (3) Oscilloscope

## 4. EXPERIMENTS AND RECORDS

### *Experiment 1-1 Colpitts Oscillator*

- (1) Locate Colpitts Oscillator circuit on Module KL-93001. Insert connect plugs in J1 and J3 to set  $C_3 = 0.001\mu\text{F}$ ,  $C_4 = 0.015\mu\text{F}$  and  $L_1 = 27\mu\text{H}$ .
- (2) Set the vertical input of oscilloscope to AC position and connect to output terminals (O/P). Observe and record the waveform and frequency in Table 1-1. If the circuit operates improperly, recheck the dc bias of transistor.
- (3) Use formula to calculate the output frequency and record the results in Table 1-1. Use formula to calculate the output frequency.
- (4) Insert connect plugs in J2 and J4 to change  $C_3$  to  $C_5$  (100 pF),  $C_4$  to  $C_6$  (1000 pF), and  $L_1$  to  $L_2$  (2.7 $\mu\text{H}$ ). Repeat steps 2 and 3.

### *Experiment 1-2 Hartley Oscillator*

- (1) Locate Hartley Oscillator circuit on Module KL-93001. Insert connect plugs in J1 and J3 to set  $L_1 = 68\mu\text{H}$ ,  $L_2 = 2.7\mu\text{H}$ , and  $C_3 = 100\text{pF}$ .
- (2) Set the vertical input of oscilloscope to AC position and connect to output terminals (O/P). Observe and record the waveform and frequency in Table 1-2. If the circuit operates improperly, recheck the dc bias of transistor.
- (3) Use formula to calculate the output frequency and record the results in Table 1-2.
- (4) Insert connect plugs in J2 and J4 to change  $C_3$  to  $C_4$  (150 pF),  $L_1$  to  $L_3$  (47 $\mu\text{H}$ ), and  $L_2$  to  $L_4$  (470  $\mu\text{H}$ ). Repeat steps 2 and 3.

## 5. QUESTIONS

- (1) In experiments 1-1 and 1-2, do the calculated and measured values of output signal agree? Explain.
- (2) What is the function of each capacitor or inductor in Colpitts oscillator circuit shown in Fig. 1-3?
- (3) Determine the values of  $C_3$ ,  $L_1$  and  $L_2$  of Hartley oscillator shown in Fig.1-5 for the oscillating frequency of 5MHz.
- (4) When the operating frequency is in radio-frequency range, why we must pay attention to the layout of circuit and the length of wire?

Table 1-1

	$C_3$	$C_4$	$L_1$	Output Waveform
Nominal Value	0.001 $\mu\text{F}$	0.015 $\mu\text{F}$	27 $\mu\text{H}$	
Measured Value				Calculated $f_0 =$ Measured $f_0 =$
Nominal Value	100 $\text{pF}$	1000 $\text{pF}$	2.7 $\mu\text{H}$	
Measured Value				Calculated $f_0 =$ Measured $f_0 =$



Table 1-2

	$L_1$	$L_2$	$C_3$	Output Waveform
Nominal Value	68 $\mu\text{H}$	2.7 $\mu\text{H}$	100 pF	
Measured Value				Calculated $f_0 =$ Measured $f_0 =$
Nominal Value	470 $\mu\text{H}$	47 $\mu\text{H}$	150 pF	
Measured Value				Calculated $f_0 =$ Measured $f_0 =$

## SECOND ORDER FILTER

### 1. OBJECTIVES

- (1) Understanding the characteristics of filters.
- (2) Understanding the advantages of active filters.
- (3) Implementing second-order filters with integrator circuit.

### 2. DISCUSSION OF FUNDAMENTALS

Filters, which exist everywhere in communication systems, are designed to pass a specified band of frequencies while attenuating all signals outside this band.

Filters are usually classified according to filtering range, frequency response in pass band, and circuit component. Classified by filtering range, there are four types of filters: low-pass, high-pass, band-pass, and band-reject filters. According to frequency response in pass band, there are two types: Butterworth and Chebyshev filters. According to circuit component, they are active and passive filters.

Passive filters are the circuits that contain only passive components (resistors, inductors and capacitors) connected in such a way that they will pass certain frequencies while rejecting others. Active filters, which are the only type covered in this chapter, employ active components (transistors or operational amplifiers) plus resistors, inductors and capacitors. Active filters are widely used in modern communication systems, because they have the following advantages:

- (1) Because the transfer function with inductive characteristic can be achieved by particular circuit design, resistors can be used instead of inductors.
- (2) The high input impedance and low output impedance of the operational amplifier means that the filter circuit is excellent in isolation characteristic and suitable for cascade.
- (3) Because active components provide amplification, therefore active filters have gain.

In the following sections, we will focus on the characteristics of the second-order low-pass and high-pass active filters.

#### Second-Order Low-Pass Filter

A low-pass filter is an electronic circuit that has a constant output voltage from dc up to a cutoff frequency. As the frequency increases above the cutoff frequency, the output voltage is

attenuated. The cutoff frequency, also called the 0.707 frequency, the 3dB frequency, or the corner frequency, is the frequency where the output voltage is reduced to 0.707 times its pass band value. A typical active low-pass filter circuit, shown in Fig. 2-1, is commonly called inverting integrator or Miller integrator. Its transfer function can be expressed by

$$\frac{V_{out}(S)}{V_{in}(S)} = \frac{-\frac{1}{SC}}{\frac{R}{S}} = \frac{-\frac{1}{RC}}{S} = \frac{-\omega_0}{S} \quad (2-1)$$

Where  $\omega_0 = \frac{1}{RC}$

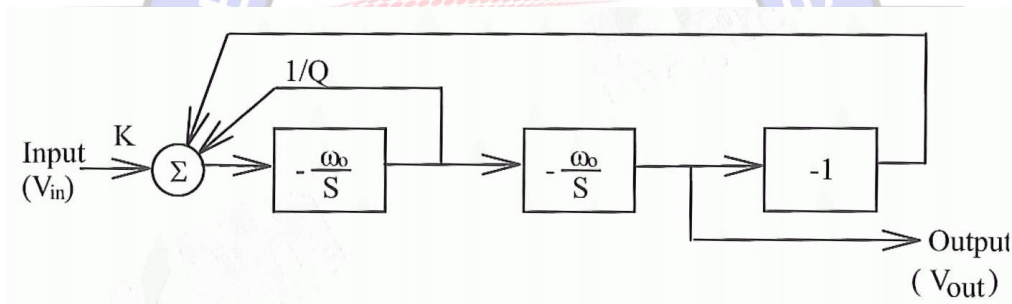
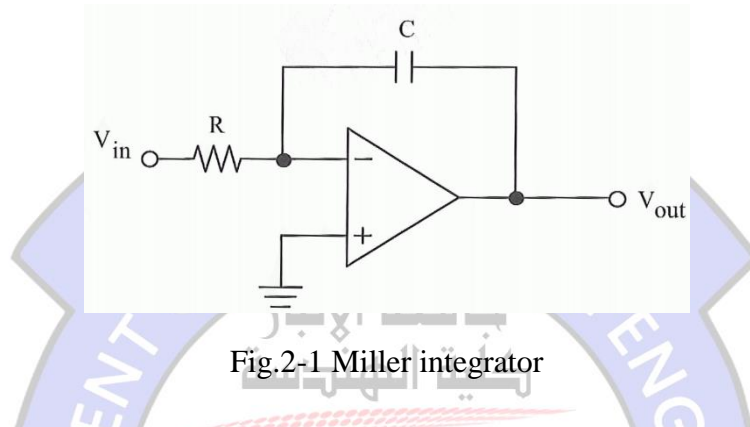

From Eq. (2-1), we can find that the Miller integrator circuit is a first-order low-pass filter. Therefore, a second-order low-pass filter can be easily constructed by cascading two Miller integrators with an inverting amplifier.

The block diagram of second-order low-pass filter, shown in Fig. 2-2, is consisted of two Miller integrators, a unity-gain inverting amplifier and adder. Therefore, the transfer function is

$$\frac{V_{out}(S)}{V_{in}(S)} = \frac{K\omega_0^2}{S^2 + \left(\frac{\omega_0}{Q}\right)S + \omega_0^2} \quad (2-2)$$

This is a general form of second-order low-pass filter. Following this block diagram, a practical second-order low-pass filter is indicated in Fig. 2-3. In this circuit, the operational amplifier

U<sub>1</sub>:A performs the functional combination of the adder and the first Miller integrator in Fig. 2-

2. If C<sub>1</sub>=C<sub>2</sub>=C and R<sub>6</sub>=R<sub>5</sub>=R<sub>4</sub> the transfer function will be

$$\frac{V_{out}(S)}{V_{in}(S)} = \frac{\frac{R_3}{R_1} \frac{1}{R_3 R_4 C^2}}{S^2 + \frac{1}{CR_2} S + \frac{1}{R_3 R_4 C^2}} = \frac{\frac{R_3}{R_1} \frac{1}{R_3 R_4 C^2}}{S^2 + \frac{\sqrt{R_3 R_4}}{R_2} \frac{1}{C\sqrt{R_3 R_4}} S + \frac{1}{R_3 R_4 C^2}} \quad (2-3)$$

Comparing Eqs. (2-2) to (2-3), we yield

$$K = \frac{R_3}{R_1} \quad (2-4)$$

$$\omega_0 = \frac{1}{C\sqrt{R_3 R_4}} \quad (2-5)$$

$$Q = \frac{R_2}{\sqrt{R_3 R_4}} \quad (2-6)$$

In the circuit of Fig. 2-3, the components R<sub>1</sub>, R<sub>2</sub>, R<sub>3</sub>, C<sub>1</sub> and U<sub>1</sub>:A form the Miller integrator with the function of weighted adder. The adder is used to add the input signal to the feedback signal from the U<sub>1</sub>:C output. The combination of R<sub>4</sub>, C<sub>2</sub> and U<sub>1</sub>:B is the second miller integrator and the combination of R<sub>5</sub>, R<sub>6</sub> and U<sub>1</sub>:C is a unity-gain inverting amplifier. Since this circuit design satisfies the Butterworth criteria, the response curve in its pass band is flat and no ripple.

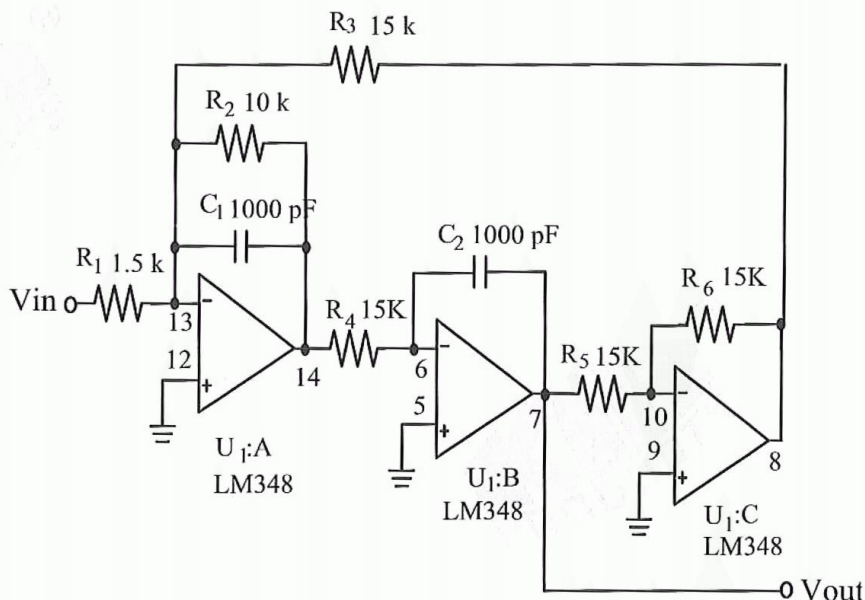

Fig.2-3 Second-order low-pass filter circuit

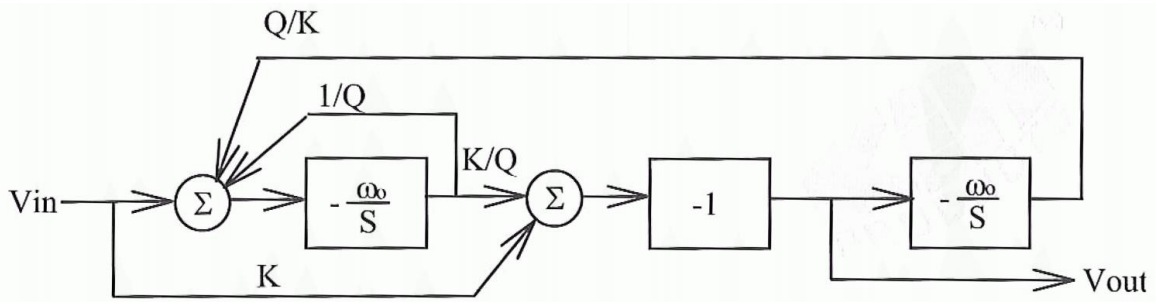

Fig.2-4 Block diagram of a second-order high-pass filter

### Second-Order High-Pass Filter

The frequency response of a second-order high-pass filter is opposite to that of a second-order low-pass filter. A high-pass filter attenuates the output voltage for all frequencies below the cutoff frequency. Above the cutoff frequency, the magnitude of the output voltage is constant. The block diagram of Fig. 2-4 is a second-order high-pass filter constructed by two Miller integrators, an inverting amplifier and two adders. Its transfer function can be given by

$$\frac{V_{out}(S)}{V_{in}(S)} = \frac{-KS^2}{S^2 + \left(\frac{\omega_0}{Q}\right)S + \omega_0^2} \quad (2-7)$$

This is a general form of second-order high-pass filters. Following this block diagram, a practical second-order high-pass filter is indicated in Fig. 2-5.

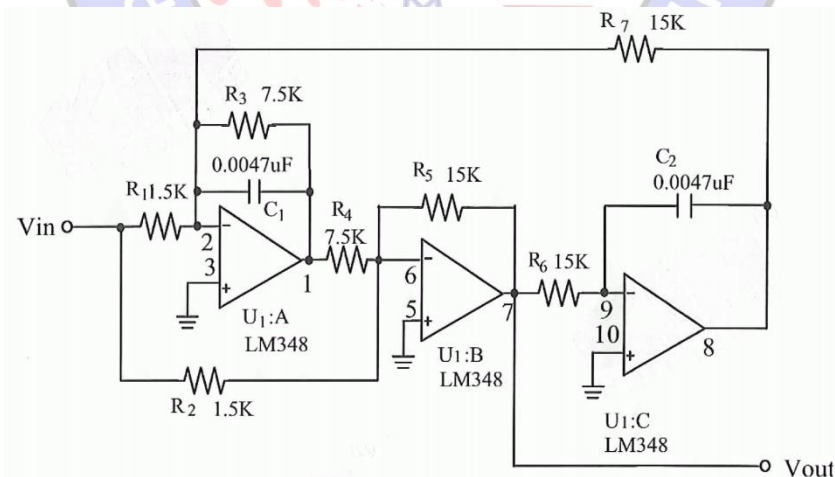

Fig.2-5 Second-order high-pass filter circuit

Comparing these two figures, the U<sub>1</sub>:A performs the functional combination of the first adder and Miller integrator. The U<sub>1</sub>:B performs the functional combination of the second adder and the unity-gain inverting amplifier. If C<sub>1</sub>=C<sub>2</sub>=C and R<sub>7</sub>=R<sub>6</sub>=R<sub>5</sub> the transfer function will be

$$\frac{V_{out}(S)}{V_{in}(S)} = \frac{-\frac{R_5}{R_2} S^2 - \frac{R_5}{CR_2} \left( \frac{1}{R_3} - \frac{R_2}{R_1 R_4} \right)}{S^2 + \frac{1}{R_3 C} S + \frac{1}{R_4 R_5 C^2}} \quad (2-8)$$

and if  $R_1 R_4 = R_2 R_3$  then

$$\begin{aligned} \frac{V_{out}(S)}{V_{in}(S)} &= \frac{-\frac{R_5}{R_2} S^2}{S^2 + \frac{1}{R_3 C} S + \frac{1}{R_4 R_5 C^2}} \\ &= \frac{-\frac{R_5}{R_2} S^2}{S^2 + \frac{\sqrt{R_4 R_5}}{R_3} \times \frac{1}{C \sqrt{R_4 R_5}} + \frac{1}{R_4 R_5 C^2}} \end{aligned} \quad (2-9)$$

Comparing Eqs. (2-7) to (2-9), we yield

$$K = \frac{R_5}{R_2} \quad (2-10)$$

$$\omega_0 = \frac{1}{C \sqrt{R_4 R_5}} \quad (2-11)$$

$$Q = \frac{R_3}{\sqrt{R_4 R_5}} \quad (2-12)$$

In the circuit of Fig. 2-5, the components of  $R_1$ ,  $R_3$ ,  $R_7$ ,  $C_1$  and  $U_1:A$  are connected as the first Miller integrator with the function of weighted adder. The adder is used to add the input signal to the  $U_1:C$  output signal. The second adder, constructed by  $R_2$ ,  $R_4$ ,  $R_5$  and  $U_1:B$ , is used to add the input signal to the  $U_1:A$  output signal. The components  $R_6$ ,  $C_2$  and  $U_1:C$  form the second Miller integrator circuit. Since this circuit design satisfies the Butterworth criteria, the response curve in its pass band is flat and no ripple.

All of filter circuits discussed above are second-order filters. If desired, higher order filters can be constructed by connecting these filters in cascade and modifying component values to meet Butterworth or Chebyshev criteria. The operational amplifier, used in our experiment circuits, is the LM348 that includes four OP AMPs and has the unity-gain bandwidth of 1 MHz. To improve the response in the band of high frequencies, the OP AMP LM318 can be used instead of LM348 in second-order high-pass filter circuit. The LM318 has the unity-gain bandwidth of 15MHz.

### 3. EQUIPMENT REQUIRED

- (1) Module KL-96001
- (2) Module KL-93001
- (3) Oscilloscope

### 4. EXPERIMENTS AND RECORDS

#### Experiment 2-1 Second-Order Low-Pass Filter

- (1) Locate the Second Order LPF circuit on Module KL-93001. Insert connect plugs in J1 and J2 to set  $C_1=C_2= 0.0011\mu\text{F}$ .
- (2) Connect a  $100\text{mV}_{\text{p-p}}$ , 10Hz sine wave to the input (I/P). Using the oscilloscope, observe the output signal and record the output amplitude in Table 2-1.
- (3) Observe and record the output amplitudes in Table 2-1 for input frequencies of 100Hz, 1KHz, 2KHz, 5KHz, 8KHz, 10KHz, 20KHz, 50KHz and 100KHz.
- (4) Calculate each voltage gain for each input frequency and record the results in Table 2-1.
- (5) Using the results of Table 2-1, sketch Bode plot of voltage gain in Fig. 2-6.
- (6) Remove the connect plugs from J1 and J2 and then insert them in J3 and J4 to set  $C_3=C_4=0.01\mu\text{F}$
- (7) Observe and record the output amplitude in Table 2-2 for input frequencies of 10Hz, 100Hz, 200Hz, 500Hz, 800Hz, 1KHz, 2KHz, 5KHz, 10KHz and 100KHz.
- (8) Calculate each voltage gain for each input frequency and record the results in Table 2-2.
- (9) Using the results of Table 2-2, sketch Bode plot of voltage gain in Fig. 2-7.

#### Experiment 2-2 Second-Order High-Pass Filter

- (1) Locate Second Order HPF circuit on Module KL-93001. Insert connect plugs in J1 and J2 to set  $C_1=C_2=0.0047\mu\text{F}$ .
- (2) Connect a  $100\text{mV}_{\text{p-p}}$ , 10Hz sine wave to input (I/P). Using the oscilloscope, observe the output signal and record the output amplitude in Table 2-3.
- (3) Observe and record the output amplitude in Table 2-3 for input frequencies of 100Hz, 1KHz, 2KHz, 5KHz, 8KHz, 10KHz, 20KHz, 50KHz and 100KHz
- (4) Calculate each voltage gain for each input frequency and record the results in Table 2-3
- (5) Using the results of Table 2-3, sketch Bode plot of voltage gain in Fig. 2-8.

- (6) Remove the connect plugs from J1 and J2 and then insert them in J3 and J4 to set  $C_3=C_4=0.015\mu\text{F}$
- (7) Observe and record the output amplitude in Table 2-4 for input frequencies of 10Hz, 100Hz, 200Hz, 500Hz, 800Hz, 1KHz, 2KHz, 5KHz, 10KHz and 100KHz
- (8) Calculate each voltage gain for each input frequency and record the results in Table 2-4
- (9) Using the results of Table 2-4, sketch Bode plot of voltage gain in Fig. 2-9

## 5. QUESTIONS

- (1) Derive Eq. (2-2) from the circuit of Fig. 2-2.
- (2) In Fig. 2-5, if  $R_1R_4=R_2R_3$ ,  $C_1=C_2=C$  and  $R_5=R_6=R_7$ , derive the transfer function of Eq. (2-9).
- (3) What are the advantages of active filters with OP Amps?
- (4) Inspecting Eqs. (2-5) and (2-11), which of the components can you change easily to vary the bandwidth of filter?
- (5) If we want to change the bandwidth of the filter of Fig. 2-3 to 5KHz, what capacitance values of  $C_1$  and  $C_2$  should be?

Table 2-1: ( $C_1 = C_2 = 0.001\mu\text{F}$ )

Input Frequency (Hz)	Output Amplitude (mV)	Voltage Gain (dB)
10		
100		
1k		
2k		
5k		
8k		
10k		
20k		
50k		
100k		



Table 2-2: ( $C_1 = C_2 = 0.01\mu\text{F}$ )

Input Frequency (Hz)	Output Amplitude (mV)	Voltage Gain (dB)
10		
100		
1k		
2k		
5k		
8k		
10k		
20k		
50k		
100k		

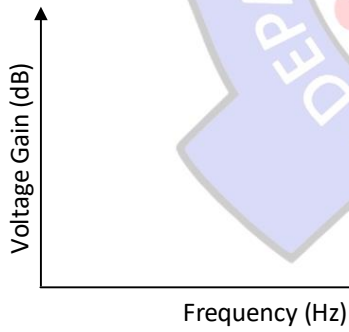

Fig. 2-6

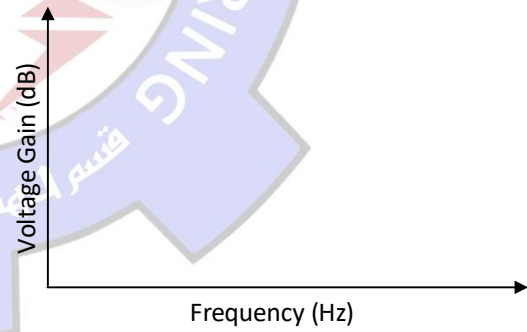

Fig. 2-7

Table 2-3: ( $C_1 = C_2 = 0.0047\mu\text{F}$ )

Input Frequency (Hz)	Output Amplitude (mV)	Voltage Gain (dB)
10		
100		
1k		
2k		
5k		
8k		
10k		
20k		
50k		
100k		

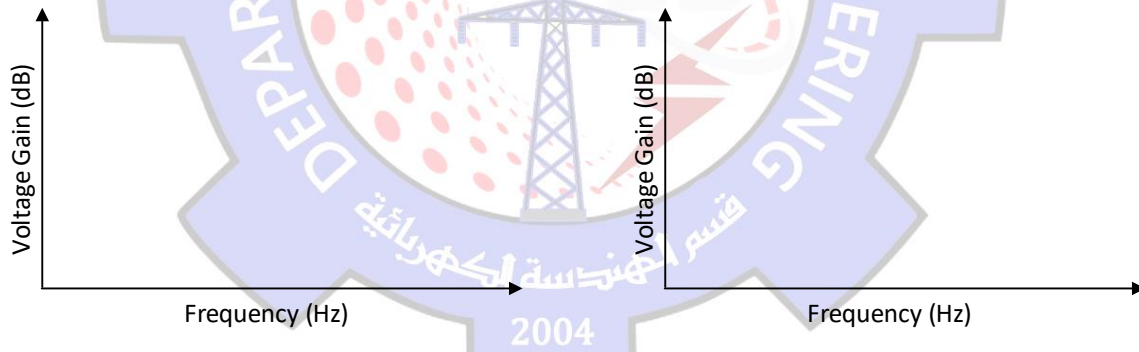
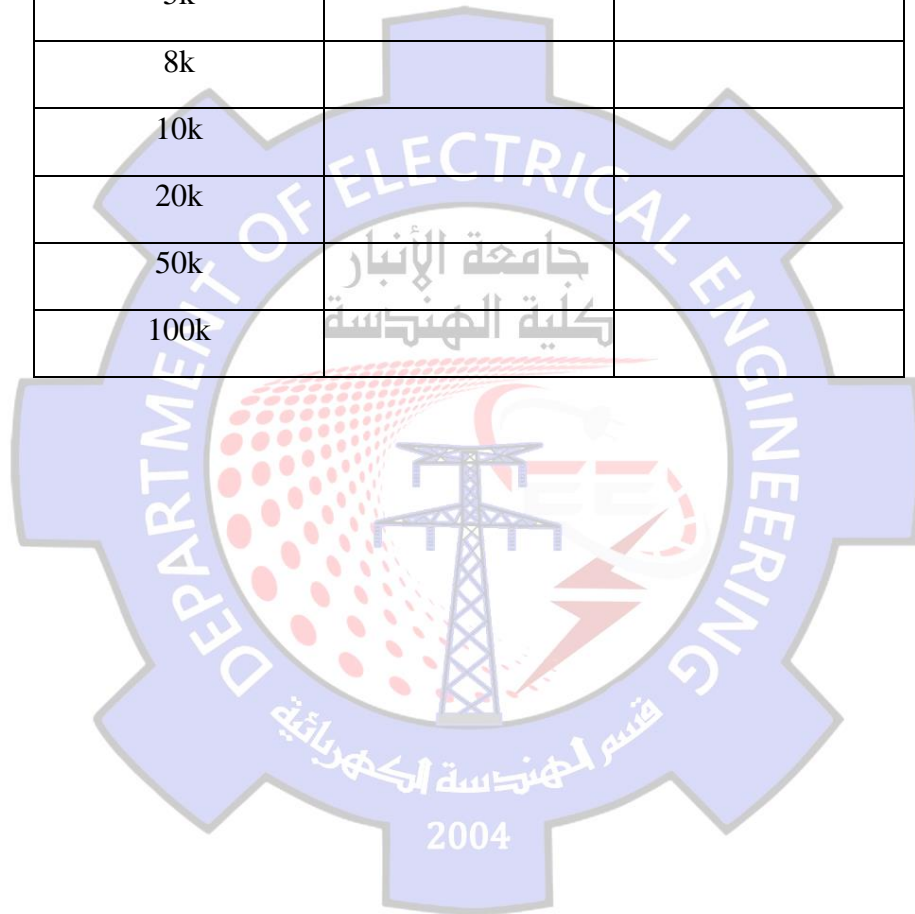

Fig. 2-8

Fig. 2-9

Table 2-4: ( $C_1 = C_2 = 0.015\mu\text{F}$ )

Input Frequency (Hz)	Output Amplitude (mV)	Voltage Gain (dB)
10		
100		
1k		
2k		
5k		
8k		
10k		
20k		
50k		
100k		



## AM MODULATORS

### 1. OBJECTIVES

- (1) Understanding the principle of amplitude modulation (AM).
- (2) Understanding the waveform and frequency spectrum of AM signal and calculating the percent of modulation.
- (3) Designing an amplitude modulator using MC1496.
- (4) Measuring and adjusting an amplitude modulator circuit

### 2. DISCUSSION OF FUNDAMENTALS

Modulation is the process of impressing a low-frequency intelligence signal onto a high-frequency carrier signal. Amplitude Modulation (AM) is a process that a high-frequency carrier signal is modulated by a low-frequency modulating signal (usually an audio). In amplitude modulation the carrier amplitude varies with the modulating amplitude, as shown in Fig. 3-1. If the audio signal is  $A_m \cos(2\pi f_m t)$  and the carrier signal is  $A_c \cos(2\pi f_c t)$ , the amplitude-modulated signal can be expressed by

$$\begin{aligned} x_{AM}(t) &= [A_{DC} + A_m \cos(\omega_m t)] A_c \cos(\omega_c t) \\ &= A_{DC} A_c [1 + m \cos(\omega_m t)] \cos(\omega_c t) \end{aligned} \quad (3-1)$$

Where:  $A_{DC}$  = dc level,  $A_m$  = audio amplitude,  $A_c$  = carrier amplitude,  $f_m$  = audio frequency,  $f_c$  = carrier frequency,  $m$  = modulation Index or depth of modulation =  $A_m/A_{DC}$ .

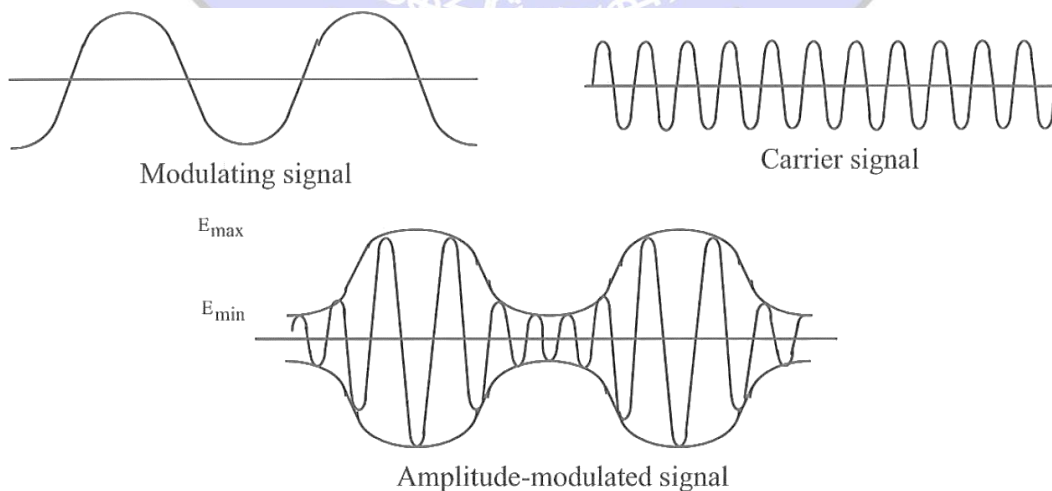

Fig.3-1 Amplitude modulation waveforms

Rewriting Eq.(3-1), we obtain

$$x_{AM}(f) = \frac{A_{DC}A_c m}{2} \left\{ \cos[2\pi(f_c + f_m)t] + \cos[2\pi(f_c - f_m)t] \right\} + A_{DC}A_c \cos(\omega_c t) \quad (3-2)$$

The first term on the right side of Eq. (3-2) represents double sideband signal and the second term is the carrier signal. According to Eq. (3-2), we can plot the spectrum of AM modulated signal as shown in Fig. 3-2. In an AM transmission the carrier frequency and amplitude always remain constant, while the side bands are constantly varying in frequency and amplitude. Thus, the carrier contains no message or information since it never changes. This means that the carrier power is a pure dissipation when transmitting an AM signal. Thus, the transmitting efficiency of amplitude modulation is lower than that of double-sideband suppressed carrier (DSB-SC) modulation, but the amplitude demodulator circuit is simpler.

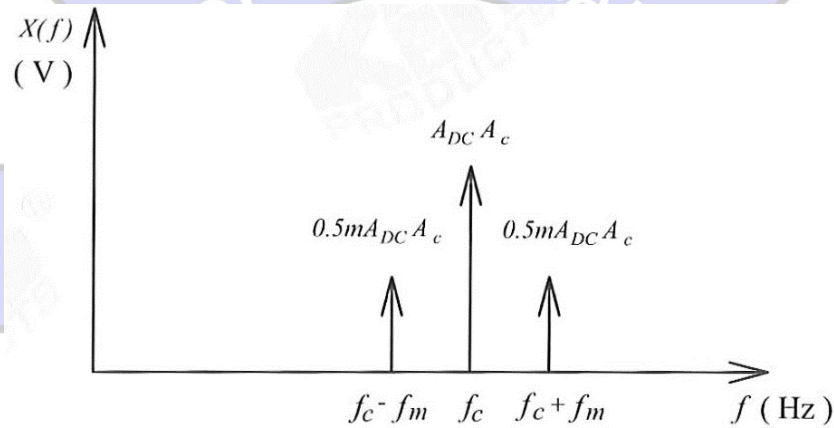

Fig.3-2 Spectrum of AM signal

The  $m$  in Eq.(3-1), called modulation index or depth of modulation, is an important parameter. When  $m$  is a percentage, it is usually called percentage modulation. It is defined as

$$m = \frac{\text{Modulation Amplitude}}{\text{DC Level}} \times 100\% = \frac{A_m}{A_{DC}} \times 100\% \quad (3-3)$$

It is difficult to measure the  $A_{DC}$  in a practical circuit so that the modulation index is generally calculated by

$$m = \frac{E_{\max} - E_{\min}}{E_{\max} + E_{\min}} \times 100\% \quad (3-4)$$

where  $E_{\max} = A_c + A_m$  and  $E_{\min} = A_c - A_m$  . as indicated in Fig. 3-1.

As mentioned above, audio signal is contained in the side bands so that the greater the sideband signals the better the transmitting efficiency. From Eq.(3-2), we can also find that the greater

the modulation index, the greater the sideband signals and the better the transmitting efficiency. In practice, the modulation index is usually less or equal to 1; if  $m > 1$ , it is called over modulation.

Table 3-1 A comparison between various balanced modulator outputs under various input frequency conditions

Carrier Input	Audio Input	Balanced Modulator Output	Circuit Characteristic
$f_c$	$f_c$	$2f_c$	Freq. Doubler
$f_c$	$f_m$	$f_c, f_c + f_m, f_c - f_m$	AM
$f_c$	$f_m$	$f_c + f_m, f_c - f_m$	DSB-SC

In the following experiments we will implement an AM modulator using a monolithic balanced modulator MC1496. According to different input signal frequencies, the MC1496 may be used as a frequency multiplier, an AM modulator, or a double sideband suppressed carrier (DSB-SC) modulator. Table 3-1 shows the summary of different input, output signals and circuit characteristics.

Fig. 3-3 shows the internal configuration of MC1496. The differential amplifier  $Q_5$  and  $Q_6$  is used to drive the differential amplifiers  $Q_1Q_2$  and  $Q_3Q_4$ . The constant-current source generator  $Q_7$  and  $Q_8$  provides the differential amplifier  $Q_5$  and  $Q_6$  with a constant current. Overall gain of MC1496 can be controlled by externally connecting a resistor between pins 2 and 3. For AM modulation, the modulating signal should be applied to pins 1 and 4, and the carrier to pins 8 and 10. The bias current to pin 5 is commonly provided by connecting a series resistor from this pin to the power supply.

Fig. 3-4 shows an AM modulator circuit whose carrier and audio signals are single-ended inputs, carrier to pin 10 and audio to pin 1. The gain of entire circuit is determined by the  $R_8$  value. The  $R_9$  determines the amount of bias current. Adjusting the amount of VR1 or the audio amplitude can change the percentage modulation.

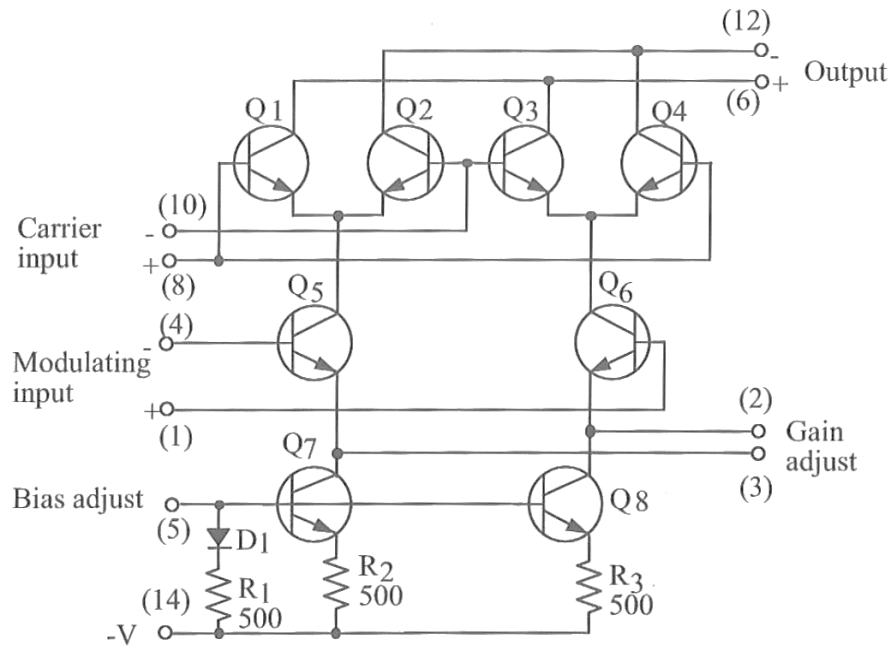

Fig.3-3 MC1496 internal circuit

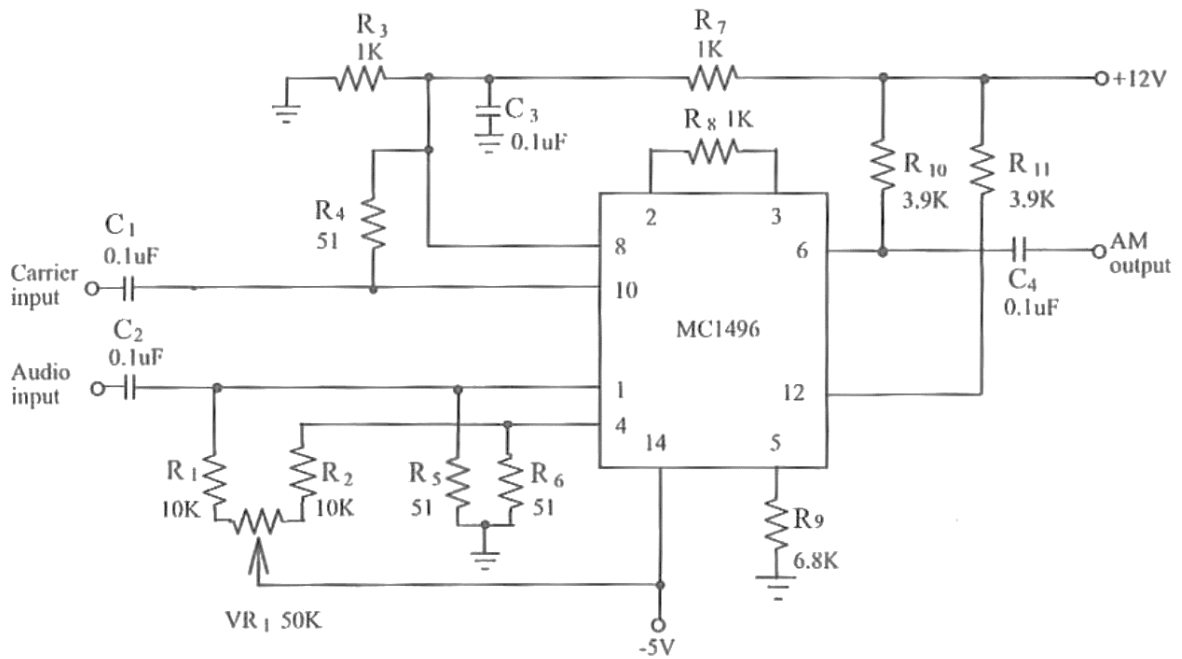

Fig.3-4 Amplitude modulator using MC1496

### 3. EQUIPMENT REQUIRED

- (1) Module KL-96001
- (2) Module KL-93002
- (3) Oscilloscope
- (4) Spectrum Analyzer
- (5) RF Generator

## 4. EXPERIMENTS AND RECORDS

### Experiment 3-1 Amplitude Modulator

- (1) Locate AM modulator circuit on Module KL-93002. Insert connect plugs in J1 and J3 to set  $R_8=1k\Omega$  and  $R_9=6.8k\Omega$ .
- (2) Connect a 250mVp-p, 1kHz sine wave to the audio input (I/P2), and a 250mVp-p, 100kHz sine wave to the carrier input (I/P1).
- (3) Connect the vertical input of the oscilloscope to the AM output (O/P). Observe the output waveform and adjust the  $VR_1$  for the modulation index of 50%. Record the result in Table 3-2.
- (4) Using the spectrum analyzer, observe & record the output signal spectrum in Table 3-2.
- (5) Using the results above and Eq. (3-4), calculate and record the percentage modulation of output signal in Table 3-2.
- (6) Using the oscilloscope, observe the output signals for the audio amplitudes of 200mVp-p and 150 mVp-p and record the results in Table 3-2.
- (7) Repeat steps 4 and 5.
- (8) Connect a 150mVp-p, 1 kHz sine wave to the input (I/P2), and a 100mVp-p, 100kHz sine wave to the carrier input (I/P1).
- (9) Using the oscilloscope, observe the AM signal at output terminal (O/P) and record the result in Table 3-3.
- (10) Using the spectrum analyzer, observe and record output spectrum in Table 3-3.
- (11) Using the results above and Eq. (3-4), calculate the percentage modulation of output signal and record the results in Table 3-3.
- (12) Repeat steps 9 to 11 for carrier amplitudes of 200mVp-p and 300mVp-p.
- (13) Connect a 150mVp-p, 3kHz sine wave to the audio input (I/P2), and a 250mVp-p, 100kHz sine wave to the carrier input (I/P1).
- (14) Using the oscilloscope, observe the modulated signal at output terminal (O/P) and record the result in Table 3-4.
- (15) Using the spectrum analyzer, observe & record the output signal spectrum in Table 3-4.
- (16) Using the results above and Eq. (3-4), calculate and record the percentage modulation of output signal in Table 3-4.
- (17) Repeat steps 14 to 16 for the audio frequencies of 2kHz and 1kHz.
- (18) Connect a 150mVp-p, 2kHz sine wave to the audio input (I/P2), and a 250mVp-p, 500kHz sine wave to the carrier input (I/P1).



- (19) Using the oscilloscope, observe the modulated signal at output terminal (O/P) and record the result in Table 3-5.
- (20) Using the spectrum analyzer, observe and record the output spectrum in Table 3-5.
- (21) Using the results above and Eq. (3-4), calculate and record the percentage modulation of output signal in Table 3-5.
- (22) Repeat steps 19 to 21 for the carrier frequencies of 1MHz and 2MHz.

### 5. QUESTIONS

- (1) In Fig. 3-4, if we change the value of  $R_8$  from  $1k\Omega$ . to  $2k\Omega$ ., what is the variation of the AM output signal?
- (2) In Fig. 3-4, if we change the value of  $R_9$  from  $6.8k\Omega$  to  $10k\Omega$ ., what is the variation in the dc bias current of the MC1496?
- (3) Determine the ratio of  $E_{max}$  to  $E_{min}$  if  $m=50\%$ .
- (4) What is the function of the  $VR_1$ ?

Table 3-2 ( $V_c=250mVp-p$ ,  $f_c=100kHz$ ,  $f_m=1kHz$ )

Audio Amplitude	Output Waveform	Output Signal Spectrum	Percentage Modulation
250mVp-p	$E_{max} =$ , $E_{min} =$		
200mVp-p	$E_{max} =$ , $E_{min} =$		
150mVp-p	$E_{max} =$ , $E_{min} =$		

Table 3-3 ( $V_m=150\text{mVp-p}$ ,  $f_c=100\text{kHz}$ ,  $f_m=1\text{kHz}$ )

Audio Amplitude	Output Waveform	Output Signal Spectrum	Percentage Modulation
100mVp-p	$E_{\max} = \quad , E_{\min} =$		
200mVp-p	$E_{\max} = \quad , E_{\min} =$		
300mVp-p	$E_{\max} = \quad , E_{\min} =$		

Table 3-4 ( $V_c=250\text{mVp-p}$ ,  $V_m=150\text{mVp-p}$ ,  $f_c=100\text{kHz}$ )

Audio Frequency	Output Waveform	Output Signal Spectrum	Percentage Modulation
3kHz	$E_{\max} = \quad , E_{\min} =$		
2kHz	$E_{\max} = \quad , E_{\min} =$		
1kHz	$E_{\max} = \quad , E_{\min} =$		

Table 3-5 ( $V_c=250\text{mVp-p}$ ,  $V_m=150\text{mVp-p}$ ,  $f_m=2\text{kHz}$ )

Carrier Frequency	Output Waveform	Output Signal Spectrum	Percentage Modulation
500kHz	$E_{\max} =$ , $E_{\min} =$		
1MHz	$E_{\max} =$ , $E_{\min} =$		
2MHz	$E_{\max} =$ , $E_{\min} =$		

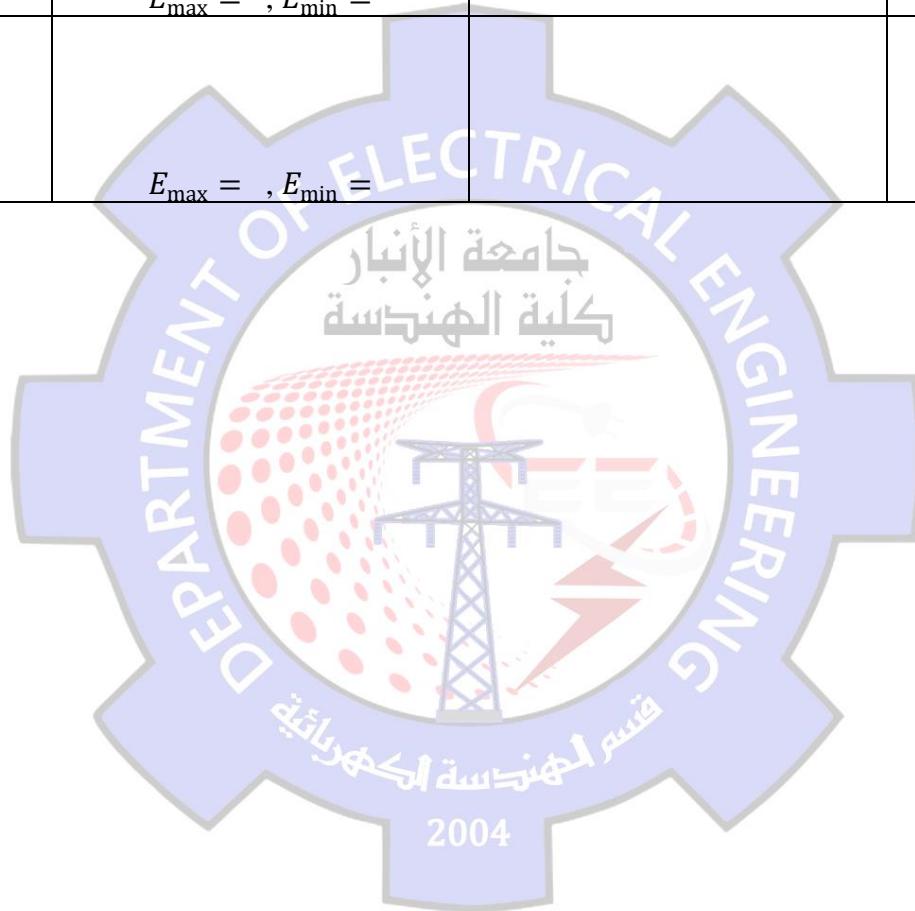

## AM DEMODULATORS

### 1. OBJECTIVES

- (1) Understanding the principle of amplitude demodulation.
- (2) Implementing an amplitude demodulator with diode.
- (3) Implementing an amplitude demodulator with a product detector.

### 2. DISCUSSION OF FUNDAMENTALS

A demodulation process is just the opposition of a modulation process. As noticed in Chapter 3, an AM signal is a modulated signal that is high-frequency carrier amplitude varied with low-frequency audio amplitude for transmission. To recover the audio signal in receiver, it is necessary to extract the audio signal from an AM signal. The process of extracting a modulating signal from a modulated signal is called demodulation or detection. It is shown in Fig. 4-1. In general, detectors can be categorized into two types: synchronous and asynchronous detectors. We will discuss these two types of AM detectors in the rest of this chapter.

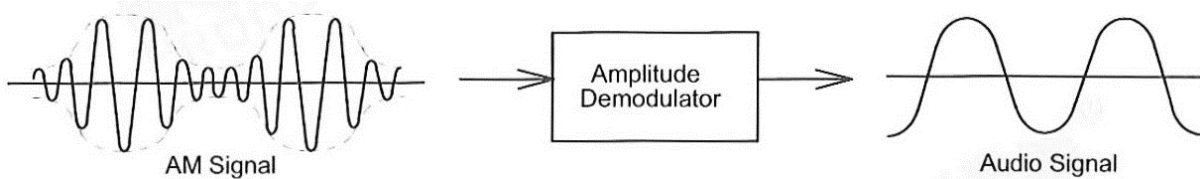

Fig.4-1 Illustration of an amplitude demodulation

#### Diode Detector

Since an AM modulated signal is the signal that the carrier amplitude varies with the modulating amplitude, a demodulator is used to extract the original modulating signal from the AM signal.

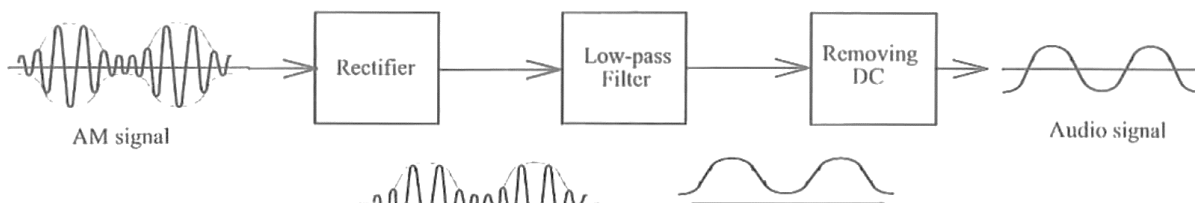

Fig.4-2 Block diagram of a rectified demodulator

The block diagram of diode detector, shown in Fig. 4-2, is a typical asynchronous detector. The AM modulated signal including both positive-half and negative-half envelope waves is applied to the input of the rectifier. The rectified output signal is the positive half envelope plus a dc

level and is fed into a low-pass filter whose output is the original modulating signal with dc level. Then the modulating signal will be recovered by removing the dc voltage.

Fig. 4-3 shows a practical diode detector circuit. The components  $R_1, R_2, R_3, R_4, U_1$  and  $U_2$  constitute two inverting amplifiers connected in cascading to offer a proper gain for the AM signal. The amplified AM signal is rectified by  $D_1$  diode and then fed into the input of the low-pass filter constructed by  $C_2, C_3$  and  $R_5$ . The output signal of low-pass filter is the positive-half envelope with a dc level. The capacitor  $C_4$  is used to pass the ac components while blocking the dc component.

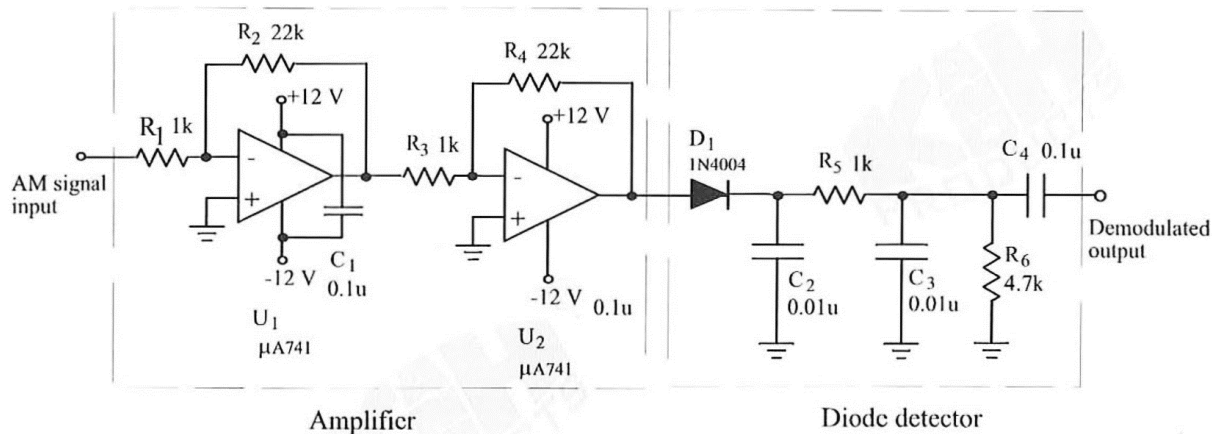

Fig.4-3 Diode detector circuit

### Product Detector

Demodulation for AM signal can be also accomplished with the balanced modulator discussed before. Such demodulator is called synchronous detector or product detector. Fig. 4-4 provides the internal circuit of MC1496 balanced modulator. See the discussion in Chapter 3 for details. If  $x_{AM}(t)$  represents the AM signal and  $x_c(t)$  is the carrier, and are expressed by

$$x_{AM}(t) = V_{DC} \left\{ 1 + m \cos(\omega_m t) \right\} \left\{ V_c \cos(\omega_c t) \right\} \quad (4-1)$$

$$x_c(t) = V_c \cos(\omega_c t) \quad (4-2)$$

If these two signals are connected to the inputs of balance demodulator, then the output of balance demodulator will be

$$\begin{aligned} x_{out}(t) &= kx_c(t) \times x_{AM}(t) \\ &= \frac{kV_{DC}V_c^2}{2} + \frac{kV_{DC}V_c^2}{2} m \cos(\omega_m t) + \frac{kV_{DC}V_c^2}{2} \left\{ 1 + m \cos(\omega_m t) \right\} \cos(2\omega_c t) \end{aligned} \quad (4-3)$$

where  $k$  is the gain of balanced modulator. The first term on the right side of Eq.(4-3) represents dc level, the second term is the modulating signal, and the third term is the second-order harmonic signal. To recover the modulating signal, the intelligence must be extracted from the AM signal  $x_{out}(t)$ .

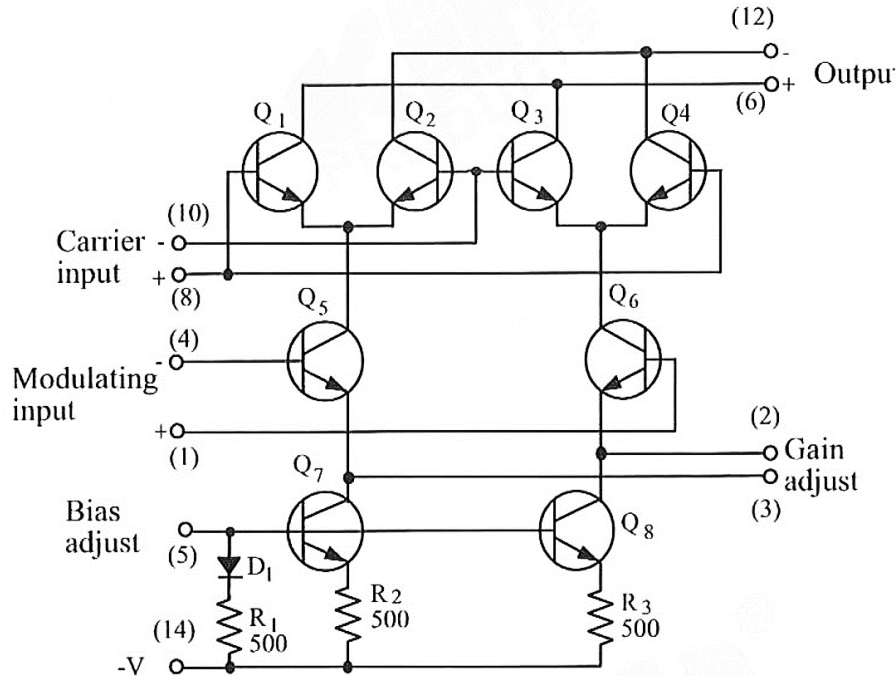

Fig. 4-4 MC 1496 internal circuit

Fig. 4-5 shows the product detector circuit. The  $VR_1$  controls the input level of the carrier signal. The output signal from the MC1496 pin 12 is expressed by Eq. (4-3). The low-pass filter constructed by  $C_7$ ,  $C_9$  and  $R_9$  is used to remove the third term, which is the second-order harmonic signal in the AM modulated signal. The first term of Eq. (4-3) is the dc level that can be blocked by the capacitor  $C_{10}$ . The amplitude demodulated output signal can be given by

$$x_{out}(t) = \frac{kV_{DC}V_c^2}{2} m \cos(\omega_m t) \quad (4-4)$$

Eq. (4-4) represents the audio signal. In other words, the product detector has extracted the audio signal from the AM signal.

From the discussion above, we can conclude that the diode detector is an asynchronous detector whose circuit is simple but quality is bad. The product detector is a synchronous detector whose quality is excellent but the circuit is more complicated and the carrier signal must exactly synchronize with the AM signal.

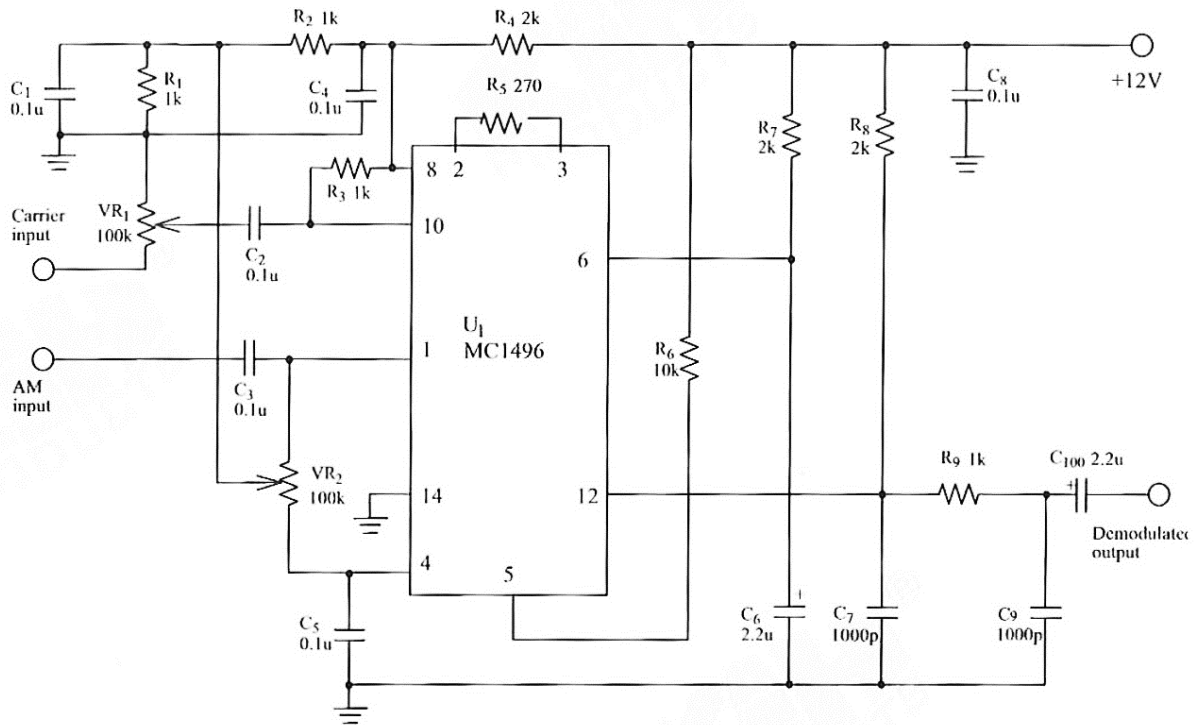

Fig. 4-5 Product detector circuit

### 3. EQUIPMENT REQUIRED

- (1) Module KL-96001
- (2) Module KL-93002
- (3) Oscilloscope
- (4) RF Generator

### 4. EXPERIMENTS AND RECORDS

#### Experiment 4-1 Diode Detector

- (1) The AM signal source in this experiment is from the AM modulator output accomplished in Chapter 3 (the circuit of Fig. 3-4).
- (2) Set the input signals of AM modulator for the carrier of 250mVp-p, 200kHz sine wave, and the audio signal of 150mVp-p, 3kHz sine wave.
- (3) Adjust the VR1 of AM modulator to get maximum amplitude of AM signal output.
- (4) Connect the AM signal output to the input (I/P) of diode detector.
- (5) Switch the vertical input of scope to DC coupling and observe the output waveforms of the amplifier and the diode detector, and record the results in Table 4-1.
- (6) Change the audio frequencies for 2kHz and 1kHz, and repeat step 5.

- (7) Adjust the carrier to a 250mVp-p, 300kHz sine wave, and the audio to a 250mVp-p, 3kHz sine wave
- (8) Adjust the VR1 of AM modulator to get maximum amplitude of AM signal output.
- (9) Set the vertical input of scope to DC coupling and observe the output waveforms of the amplifier and the diode detector, and record the results in Table 4-2.
- (10) Change the audio frequencies for 2kHz and 1kHz, and repeat step 9.

#### Experiment 4-2 Product Detector

- (1) The AM signal source in this experiment is from the AM modulator output accomplished in Chapter 3 (the circuit of Fig. 3-4).
- (2) Set the input signals of AM modulator for the carrier of 250mVp-p, 500kHz sine wave, and the audio signal of 150mVp-p, 3kHz sine wave.
- (3) Adjust the VR1 of AM modulator to get the percent of modulation of 50%.
- (4) Connect the output of AM modulator to the input of AM signal (I/P2) of the product detector located on the bottom of Module KL-93002, and connect the same carrier to the carrier input (I/P1).
- (5) Switch the vertical input of scope to DC coupling and observe the output waveform of the product detector, and record the result in Table 4-3.
- (6) Change the audio frequencies for 2kHz and 1kHz, and repeat step 5.
- (7) Adjust the carrier to a 250mVp-p, 1 MHz sine wave, and the audio to a 150mVp-p, 2kHz sine wave.
- (8) Adjust the VR1 of AM modulator to get the percent of modulation of 50%.
- (9) Switch the vertical input of scope to DC coupling and observe the output waveform of the product detector, and record the result in Table 4-4.
- (10) Change the carrier frequencies for 1.5MHz and 2MHz, and repeat step 9.

#### 5. QUESTIONS

- (1) In the diode detector circuit of Fig. 4-3, if the operational amplifier  $\mu A741$  is neglected, what is the output signal?
- (2) In the product detector circuit of Fig. 4-5, if the carrier signal and the AM signal are asynchronous, what is the output signal?
- (3) What is the function of  $R_9$ ,  $C_7$  or  $C_9$  in Fig. 4-5?
- (4) What is the function of  $VR_1$  or  $VR_2$  in Fig. 4-5?
- (5) What is the function of  $R_5$  or  $R_6$  in Fig. 4-5?



Table 4-1 ( $V_c=250\text{mVp-p}$ ,  $V_m=150\text{mVp-p}$ ,  $f_c=200\text{kHz}$ )

Audio Frequency	Input Waveform	Detector Output Waveform
3kHz		
2kHz		
1kHz		

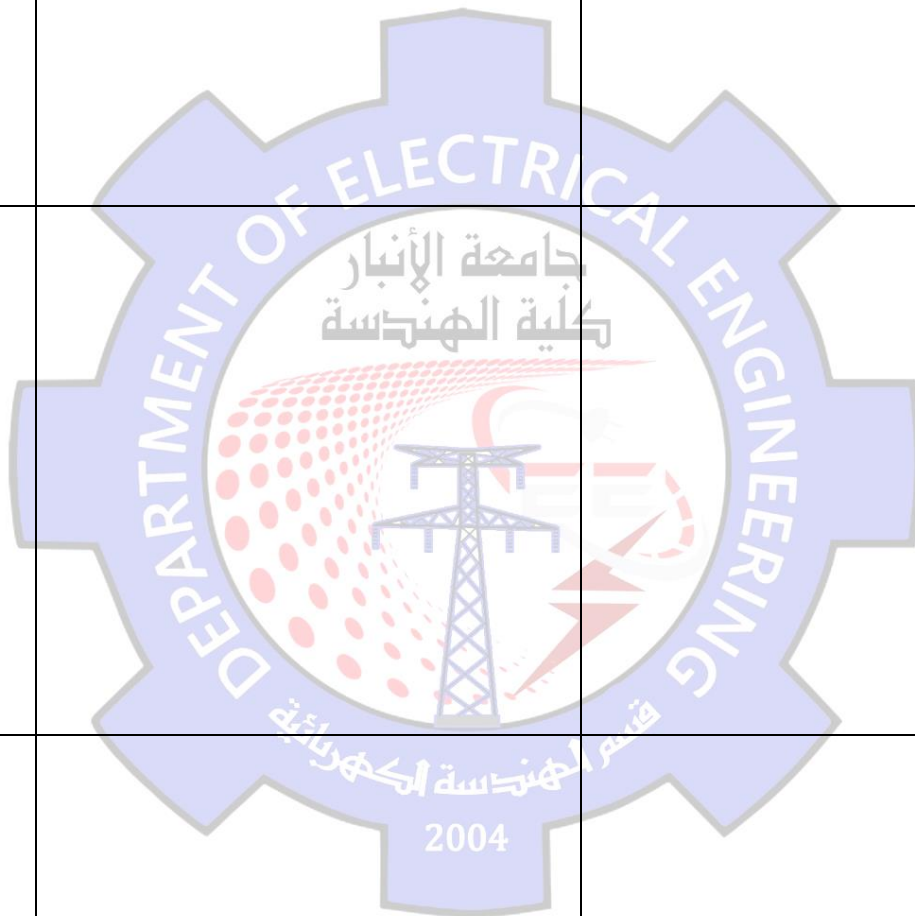

Table 4-2 ( $V_c=250\text{mVp-p}$ ,  $V_m=250\text{mVp-p}$ ,  $f_c=300\text{kHz}$ )

Audio Frequency	Input Waveform	Detector Output Waveform
3kHz		
2kHz		
1kHz		

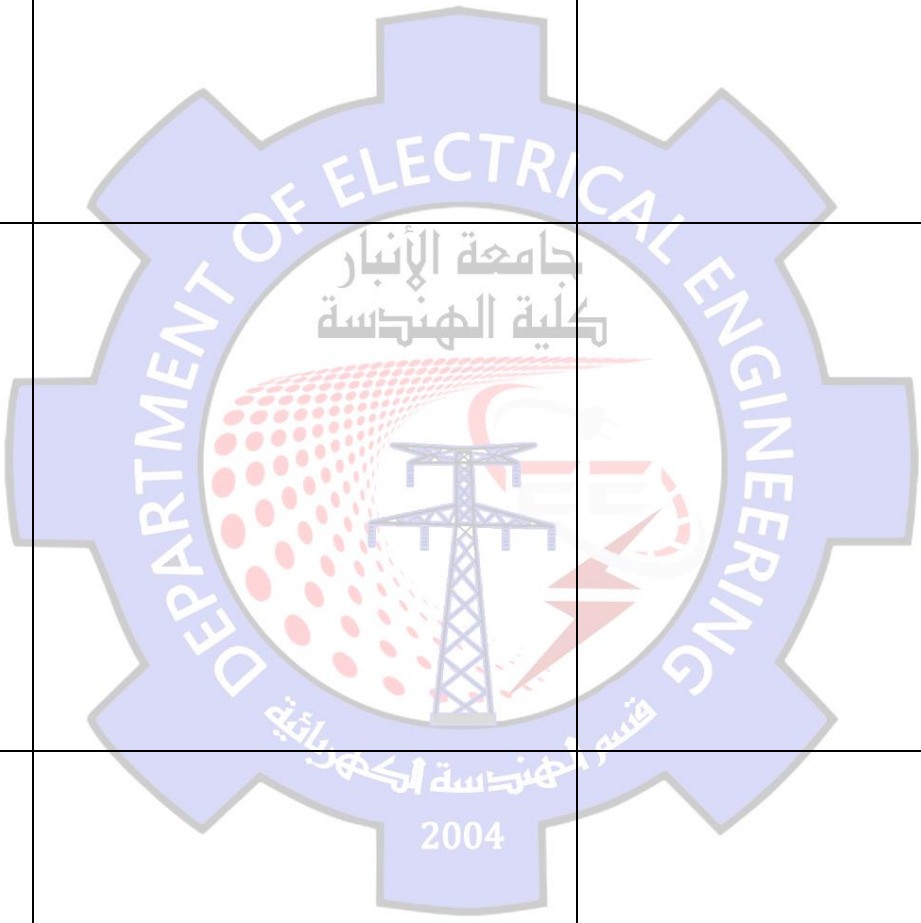

Table 4-3 ( $V_c=250\text{mVp-p}$ ,  $V_m=150\text{mVp-p}$ ,  $f_c=500\text{kHz}$ ,  $m=50\%$ )

Audio Frequency	Input Waveform	Detector Output Waveform
3kHz		
2kHz		
1kHz		

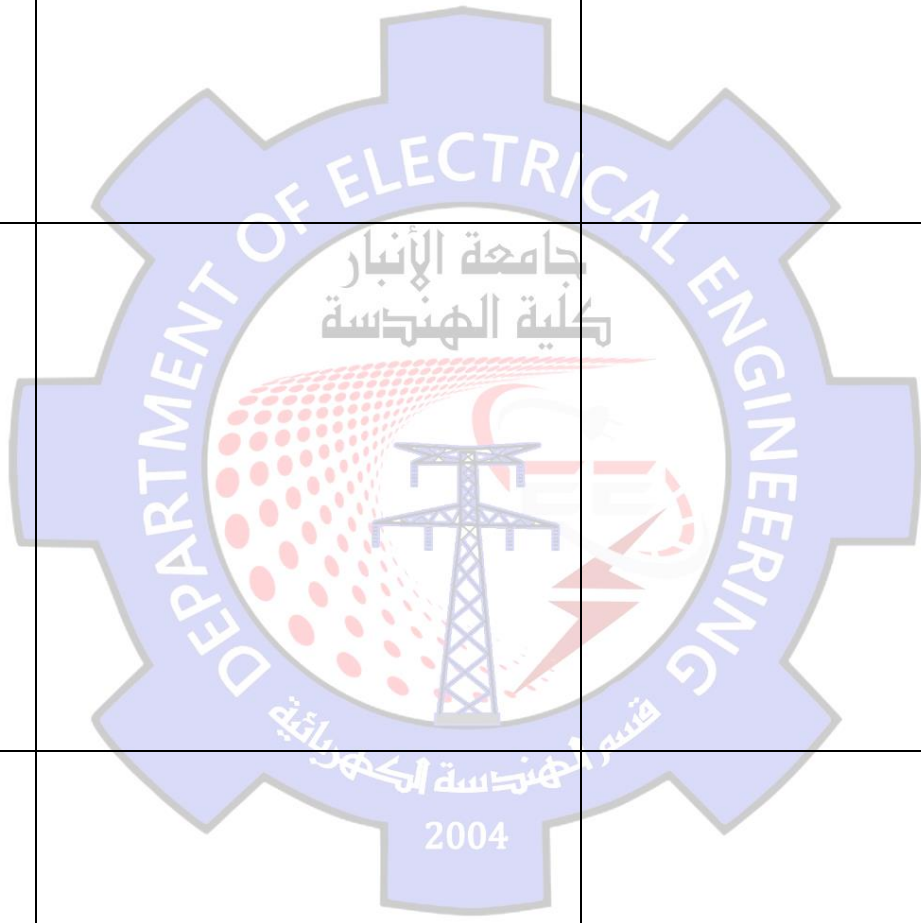
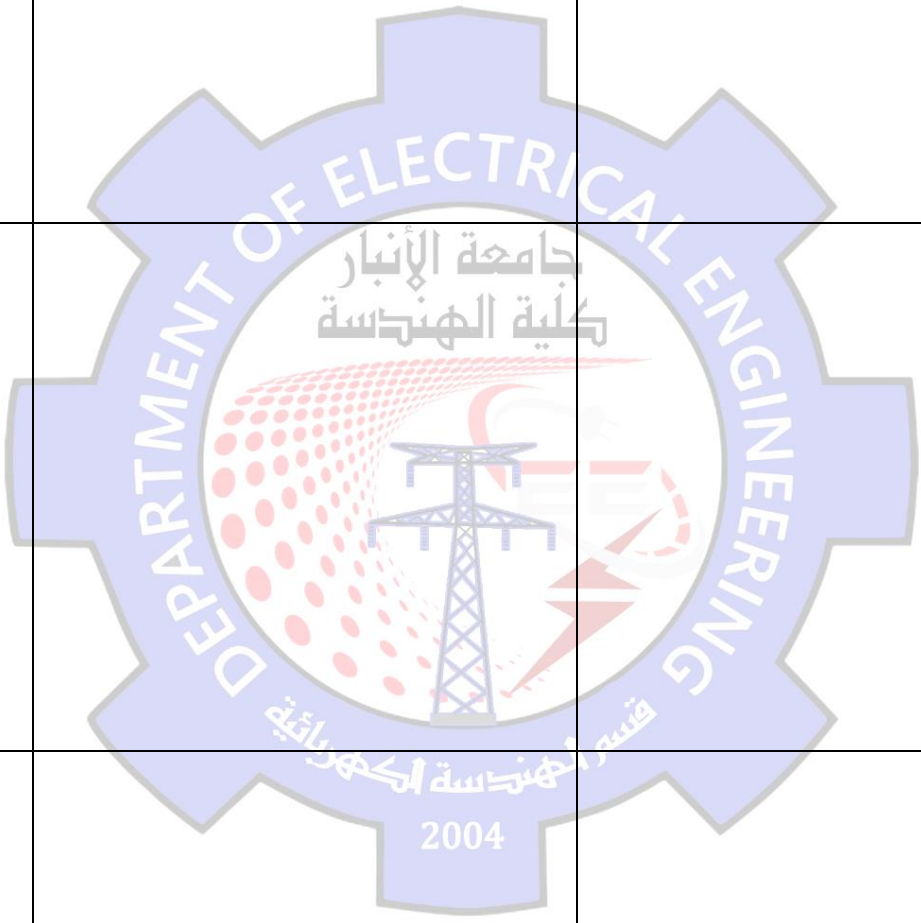

Table 4-4 ( $V_c=250\text{mVp-p}$ ,  $V_m=150\text{mVp-p}$ ,  $f_m=2\text{kHz}$ ,  $m=50\%$ )

Audio Frequency	Input Waveform	Detector Output Waveform
1MHz		
1.5MHz		
2MHz		



## VCO & FM MODULATORS

### 1. OBJECTIVES

- (1) Studying the operation and characteristics of varactor diode.
- (2) Understanding the operation of voltage-controlled oscillator.
- (3) Implementing a frequency modulator with voltage-controlled oscillator.

### 2. DISCUSSION OF FUNDAMENTALS

#### Principle of Frequency Modulation Operation

Frequency modulation (FM) is a process in which the carrier frequency is varied by the amplitude of the modulating signal (i.e., intelligence signal). The FM signal can be expressed by the following equation:

$$x_{FM}(t) = A_c \cos(\theta(t)) = A_c \cos \left[ \omega_c t + \omega_\Delta \int_0^t x(\lambda) d\lambda \right] \quad (7-1)$$

If  $x(\lambda) = A_m \cos(\omega_m \lambda)$  then

$$\begin{aligned} x_{FM}(t) &= A_c \cos[\omega_c t + \beta \sin(\omega_m t)] \\ \theta(t) &= \omega_c t + \beta \sin(\omega_m t) \end{aligned} \quad (7-2)$$

Where

$\theta(t)$  = instantaneous modulated frequency

$f_c$  = carrier frequency

$f_m$  = modulating frequency

$\beta = \frac{f_\Delta A_m}{f_m} = \text{modulation index}$

The frequency of FM signal  $x_{FM}(t)$  may be expressed as

$$\begin{aligned} f &= \frac{1}{2\pi} \frac{d}{dt} \theta(t) = \frac{1}{2\pi} \frac{d}{dt} [\omega_c t + \beta \sin(\omega_m t)] \\ &= f_c - f_m \beta \cos[\omega_m t] \end{aligned} \quad (7-3)$$

From Eq. (7-3) we can find that the frequency of frequency modulated signal occurs frequency deviation from the center frequency of the carrier when the intelligence amplitude is variation.

### Varactor Diode

The varactor diode, sometimes called tuning diode, is the diode whose capacitance is proportional to the amount of the reverse bias voltage across p-n junction. Increasing the reverse bias voltage applied across the diode decreases the capacitance due to the depletion region width becomes wider. Conversely, when the reverse bias voltage decreased, the depletion region width becomes narrower and the capacitance increased. When an ac voltage is applied across the diode, the capacitance varies with the change of the amplitude.

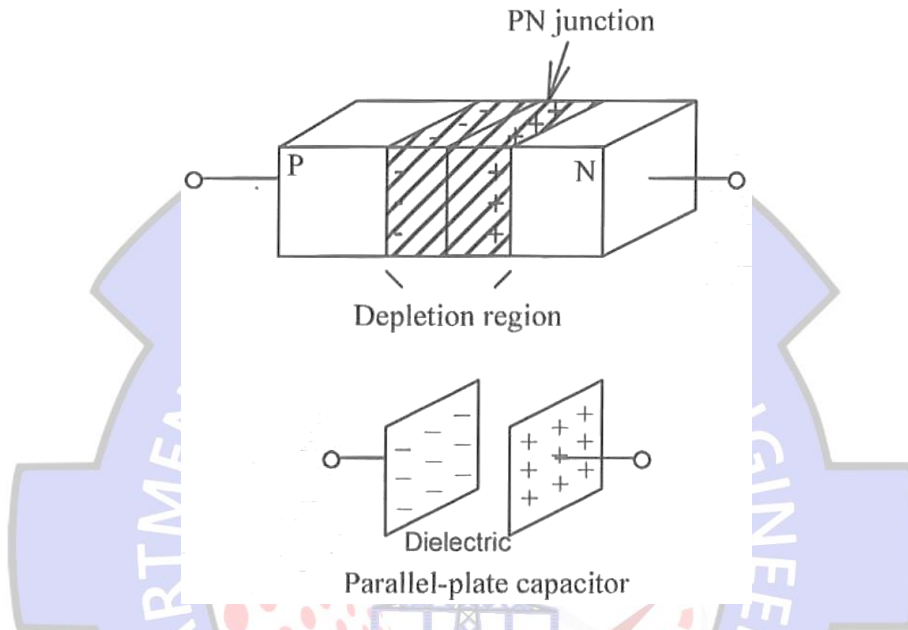

Fig. 7-1 Relationship between varactor diode and capacitor

A relationship between a varactor diode and a conventional capacitor is shown in Fig. 7-1. In fact, a reverse-biased varactor diode is similar to a capacitor. When a p and n semiconductors combined together, a small depletion region is formed because of the diffusion of minority carriers. The positive and negative charges occupy n and p sides of junction, respectively. This just likes a capacitor. The amount of internal junction capacitance can be calculated by the capacitance formula.

$$C = \frac{\epsilon A}{d} \quad (7-4)$$

Where

$\epsilon = 11.8\epsilon_0$  = dielectric constant,  $\epsilon_0 = 8.85 \times 10^{-12}$ , A = cross area of capacitor, and d = width of depletion region.

From the formula above, we know that the varator capacitance is inversely proportional to the width of depletion region (or the distance between plates) if the area A is constant. Therefore,

a small reverse voltage will produce a small depletion region and a large capacitance. In other words, an increase in reverse bias will result in a large depletion region and a small capacitance.



Fig.7-2 The equivalent circuit of varactor diode

A varactor diode can be considered as a capacitor and resistor connected in series as shown in Fig. 7-2. The  $C_j$  is the junction capacitance between p and n junctions. The  $R_s$  is the sum of bulk resistance and contact resistance, approximately several ohms, and it is an important parameter determining the quality of varactor diode.

Tuning ratio (TR) is defined as the ratio of the capacitance of varactor diode at the reverse voltage  $V_2$  to that at another reverse voltage  $V_1$ , and can be expressed by

$$TR = \frac{C_{V2}}{C_{V1}} \quad (7-5)$$

Where: TR = tuning ratio,  $C_{V1}$ =capacitance of varactor diode at  $V_1$ ,  $C_{V2}$ =capacitance of varactor diode at  $V_2$ .

The 1SV55 varactor diode is used in our experiments and its major characteristics are  $C_{3V} = 42$  pF (capacitance of varactor diode at 3V) and TR = 2.65 (at 3V~30V)

### Frequency Modulator Based on MC1648 VCO

In our experiments we will implement the frequency modulator with MC1648 VCO chip shown in Fig. 7-3. Basically, this circuit is an oscillator and the tuning circuit at input end determines its oscillating frequency. In this circuit, capacitors  $C_2$  and  $C_3$  are the bypass capacitors for filtering noise. When operating at a high frequency (for example 2.4 MHz), the capacitive reactance of these two capacitors are very small and can be neglected for practical purposes. Therefore, an ac equivalent circuit of tuning tank, shown in Fig. 7-4, is a parallel LC resonant circuit. The C can be considered as the capacitance of 1SV55 ( $C_d$ ) and the input capacitance of MC1648 ( $C_{in}$ ) connected in parallel. The value of  $C_{in}$  is approximately 6pF. If we neglect the spray capacitance, the oscillating frequency can be calculated by the formula

$$f_o = \frac{1}{2\pi\sqrt{LC}} = \frac{1}{2\pi\sqrt{L(C_d + 6 \times 10^{-12})}} \quad (\text{Hz}) \quad (7-6)$$

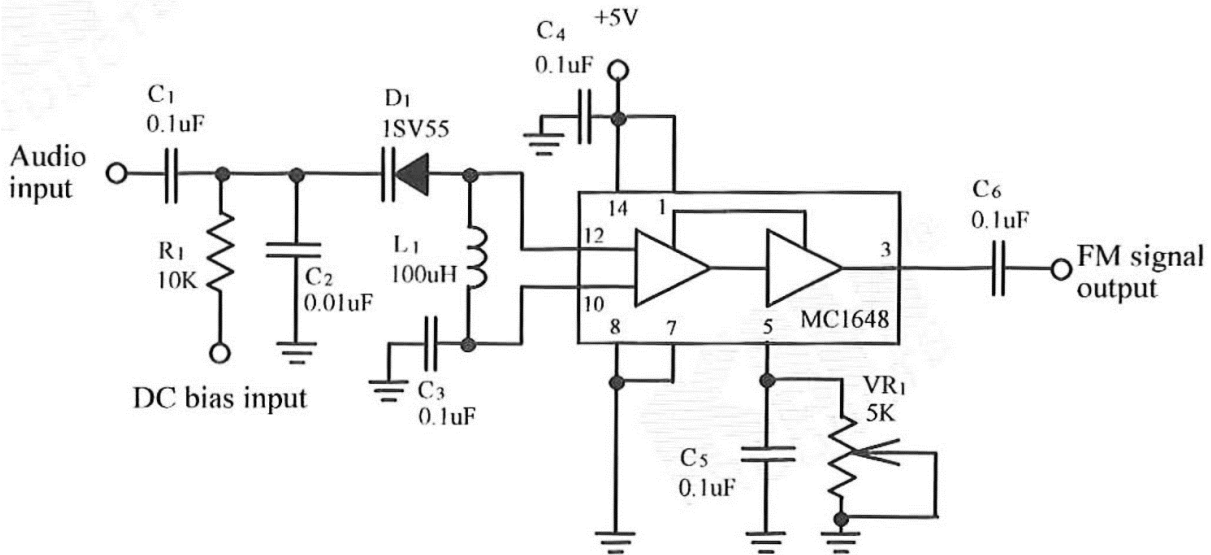

Fig.7-3 MC1648 FM modulator circuit

As mentioned above, the capacitance  $C_d$  of varactor diode  $D_1$  varies with the amount of its reverse bias voltage. According to Eq. (7-6), we know that the change of  $C_d$  value will cause the change of oscillating frequency. In the circuit of Fig. 7-3, a small dc bias will produce a large  $C_d$  value and a low frequency output. On the other hand, an increase in dc bias will result in a small  $C_d$  value and a high frequency output. Therefore, if the dc bias is fixed and an audio signal is applied to this input, the VCO output signal will be a frequency-modulated signal.

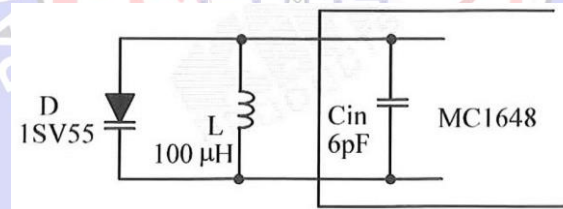

Fig.7-4 AC equivalent circuit of tuning tank

### Frequency Modulator Based on LM566 VCO

The circuit of Fig. 7-5 is a frequency modulator based on voltage-controlled oscillator (VCO) IC, LM566. If the SW1 is open, this circuit is a typical VCO whose output frequency is determined by the values of  $C_3$  and  $VR_1$ , and the audio input voltage. If the values of  $C_3$  and  $VR_1$  are fixed, the output frequency is directly proportional to the voltage difference between pins 8 and 5, ( $V_8 - V_5$ ). In other words, an increase in audio input voltage ( $V_5$ ) causes a decrease in the value of ( $V_8 - V_5$ ) and a decrease in the output frequency. Conversely, decreasing the audio input voltage ( $V_5$ ) will cause the output frequency to increase. As discussed above, the values of  $C_3$  and  $VR_1$  can also determine the output frequency, which is inversely proportional to the product of  $VR_1 \times C_3$ . That is, the greater the  $VR_1 \times C_3$  value the lower the output frequency.



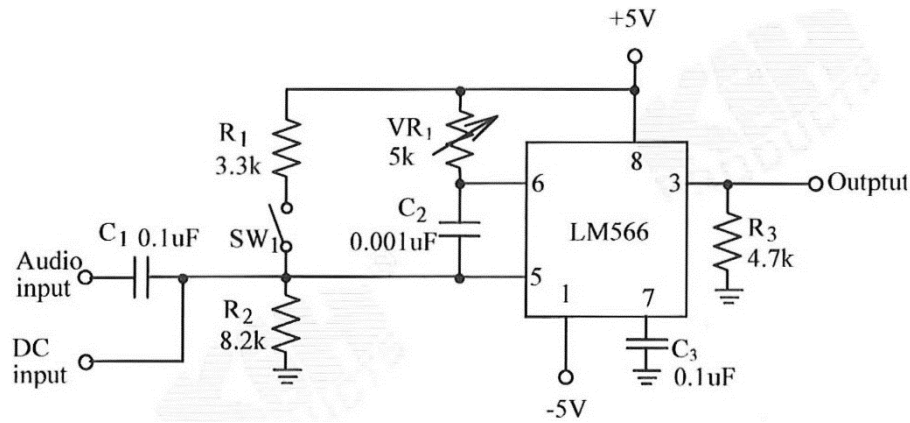

Fig.7-5 LM566 frequency modulator circuit

If the  $SW_1$  is closed, the voltage divider constructed by  $R_1$  and  $R_2$  provides a dc level to the audio input (pin 5). By adjusting the  $VR_1$ , we can easily tune the VCO center frequency  $f_o$ . When an audio signal is applied to the audio input, the output frequency will generate frequency deviations around  $f_o$  in the variations of audio amplitude. Thus, a frequency-modulated signal is obtained.

### 3. EQUIPMENT REQUIRED

- (1) Module KL-92001
- (2) Module KL-93004
- (3) Oscilloscope
- (4) Spectrum Analyzer

### 4. EXPERIMENTS AND RECORDS

#### Experiment 7-1 MC1648 Characteristic Measurements

- (1) Locate the MC1648 FM Modulator circuit on Module KL-93004. Insert the connect plug in J2 to set the inductor to  $L_1$  ( $100\mu\text{H}$ ).
- (2) Connect a 3Vdc to dc bias input (I/P2) and observe the output waveform using the oscilloscope. Adjust the  $VR_1$  until a sine wave appears at the output and record the frequency in Table 7-1.
- (3) Repeat step 2 for other dc voltages listed in Table 7-1.
- (4) Using the results of Table 7-1, plot frequency vs. voltage curve in Fig.7-6.

### Experiment 7-2 MC1648 Frequency Modulator

- (1) Insert connect plugs in J1 and J2 to reverse-bias the varactor 1SV55 at 5V and  $L_1 = 100\mu\text{LH}$ . Under these conditions, the output frequency will be the center frequency  $f_o$ .
- (2) Connect a 2Vp-p, 3kHz sine wave of to the audio input (I/P1) and observe the output waveform using the oscilloscope. Adjust the  $\text{VR}_1$  until a sine wave appears at the output.
- (3) Using the spectrum analyzer, observe and record the output spectrum in Table 7-2.
- (4) Repeat step 3 for audio frequencies of 5 kHz and 8 kHz.

Note: Since the frequency difference between the carrier and modulated signals is too large to observe an evident variation in time domain on the oscilloscope, therefore we recommend the use of the frequency analyzer in such a case.

### Experiment 7-3 LM566 Characteristic Measurements

- (1) Locate the LM566 Modulator circuit on Module KL-93004. Insert the connect plug in J2 to set the capacitor to  $C_3$  ( $0.1\mu\text{F}$ ).
- (2) Connect a 3.6Vdc to the dc voltage input (pin 5) and Adjust the  $\text{VR}_1$  to obtain an output frequency of 2kHz. This frequency is the center frequency  $f_o$ .
- (3) Change the dc voltages at pin 5 to 2.7V, 3.0V, 3.3V, 3.9V, 4.2V and 4.5V sequentially. Observe the output frequencies corresponding to the dc voltage inputs and record the results in Table 7-3
- (4) Using the results of Table 7-3, plot the frequency vs. voltage curve in Fig. 7-7.
- (5) Remove the connect plug from J2 and then insert it in J3. This changes the capacitor from  $C_3$  ( $0.1\mu\text{F}$ ) to  $C_4$  ( $0.01\mu\text{F}$ ).
- (6) Connect a 3.6Vdc to the dc voltage input (pin 5) and Adjust the  $\text{VR}_1$  to obtain an output frequency of 20kHz. This frequency is the center frequency  $f_o$ .
- (7) Change the dc voltages at pin 5 to 2.7V, 3.0V, 3.3V, 3.9 V; 4.2V and 4.5V sequentially. Observe the output frequencies corresponding to the dc voltage inputs and record the results in Table 7-4.
- (8) Using the results of Table 7-4, plot the frequency vs. voltage curve in Fig. 7-8.

### Experiment 7-4 LM566 Frequency Modulator

- (1) Locate the LM566 FM Modulator circuit on Module KL-93004. Insert connect plugs in J1 and J3 to set the capacitor to  $C_4$  ( $0.01\mu\text{F}$ ). Turn the  $\text{VR}_1$  to get the output frequency of 20kHz.

- (2) Connect a 500mVp-p, 1kHz sine wave to the audio input (I/P1). Using the oscilloscope, observe the output waveform (O/P) and record the result in Table 7-5.
- (3) Change the audio frequencies to 3kHz and 5kHz sequentially. Observe the output waveforms corresponding to the audio inputs and record the results in Table 7-5.
- (4) Change the audio input to a 1Vp-p, 1kHz sine wave. Observe the output waveform and record the result in Table 7-6.
- (5) Change the audio frequencies to 3kHz and 5kHz sequentially. Observe the output waveforms corresponding to the audio inputs and record the results in Table 7-6.

### 5. QUESTIONS

- (1) If the inductance in the tank circuit of Fig. 7-3 is 80nH and we wish to get a resonance frequency of 100MHz, what capacitance value of varactor diode should be?
- (2) Examining the Frequency vs. Voltage curve of Fig. 7-6, which portion on the curve is suitable for implementing a frequency modulator?
- (3) Reviewing the circuit of Fig.7-5, what is the function of R1 and R2 when the SW1 is closed?

Table 7-1

DC Bias Input (V)	3	4	5	6	7	8	9	10	11	12	13	14
Output Frequency (MHz)												

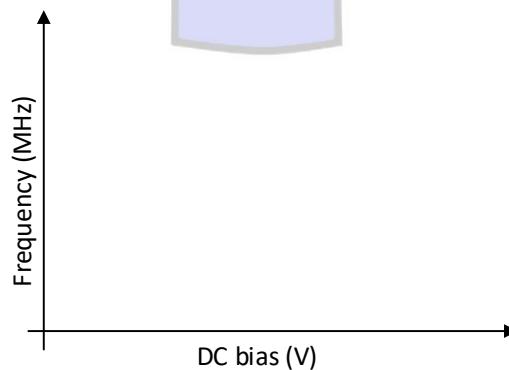

Fig.7-6

Table 7-2 ( $V_m=2V$ )

Input Frequency	Input Waveform	Output Spectrum
3kHz		
5kHz		
8kHz		

Table 7-3 ( $C_3=0.1\mu F$ ,  $f_o = 2kHz$ )

Input Voltage (V)	2.7	3.0	3.3	3.6	3.9	4.2	4.5
Output Frequency (kHz)							

Table 7-4 ( $C_3=0.01\mu F$ ,  $f_o = 20kHz$ )

Input Voltage (V)	2.7	3.0	3.3	3.6	3.9	4.2	4.5
Output Frequency (kHz)							

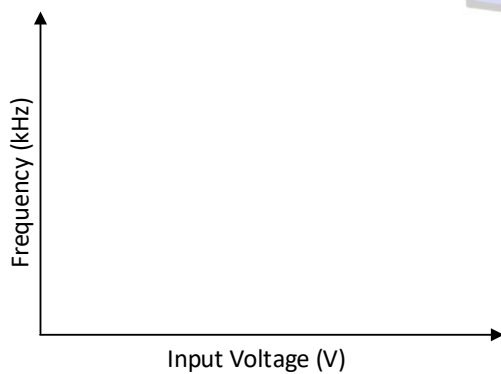

Fig.7-7

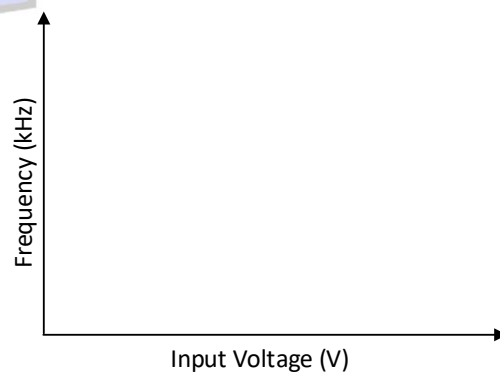

Fig.7-8

Table 7-5 ( $V_m=500mV_{p-p}$  ,  $C_3=0.01\mu F$  ,  $f_o = 20kHz$ )

Input Frequency	Input Waveform	Output Spectrum
1kHz		
3kHz		
5kHz		

Table 7-6 ( $V_m=1V_{p-p}$  ,  $C_3=0.01\mu F$  ,  $f_o = 20kHz$ )

Input Frequency	Input Waveform	Output Spectrum
1kHz		
3kHz		
5kHz		

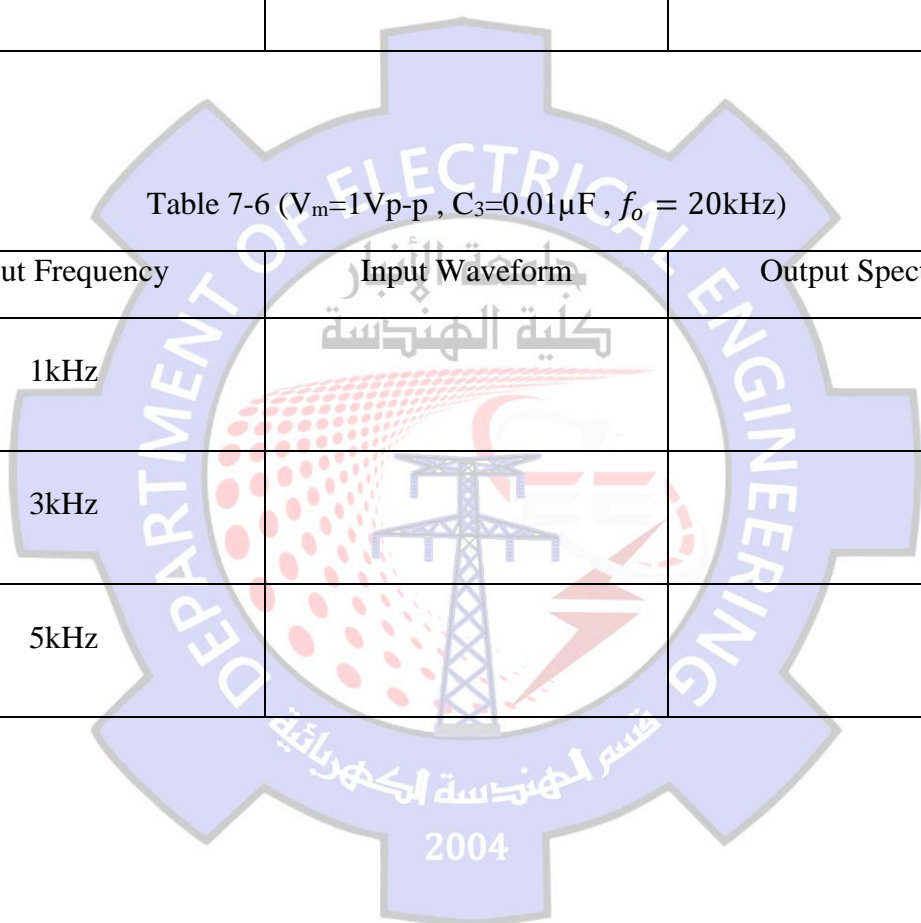

## FREQUENCY DIVISION MULTIPLEXING

### 1. DISCUSSION OF FUNDAMENTALS

#### Introduction

Many different information-bearing signals are transmitted in the same channel of radio frequency communication or many users want to transmit data at the same communication channel. There are many communication techniques to process the transmitted signals in the same time and channel, like TOM, FOM and COMA etc. This chapter introduces the FOM system.

FOM system is the technique that utilizes different channel to transmit different information-bearing signal. Take the telephone system for example, telephone A, B and C are point-to-point communication system with different transmission channel. To transmit these signals over the same channel, they must be kept apart so that they do not interfere with each other. Thus they can be separated at the receiver. The block diagram of FOM system shows in Fig. 21-1, each channel is single-sideband modulation. The Bandwidth of audio signals in telephone A, B and C are 4kHz. Signal A is modulated by carrier with 108kHz. Signal B is modulated by carrier with 104kHz and Signal C is modulated by carrier with 100kHz. The transmission bandwidth in channel A is 104 to 108kHz, in channel B is 100 to 104kHz and in channel C is 96 to 100kHz. The three modulated signals are AM subcarriers. Subcarrier is an already-modulated signal, which is then modulated into another signal of higher frequency and bandwidth for transmitting.

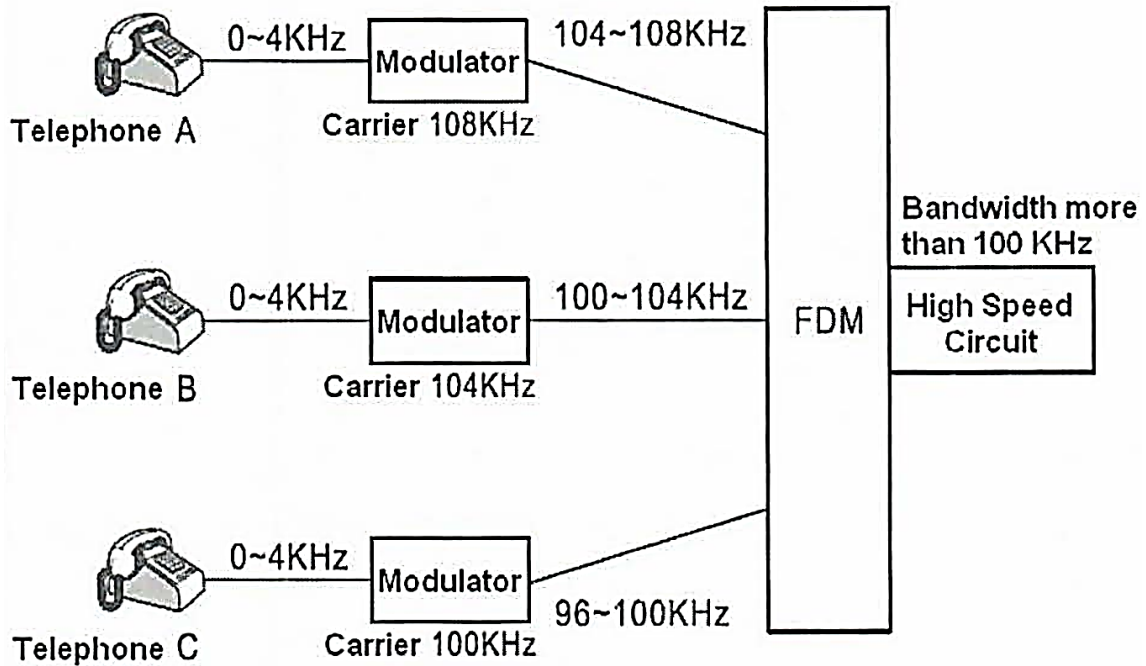

Fig. 21-1 Block diagram of FDM system

Fig. 21-2 illustrates the operation in FDM multiplexer. The three channels of telephone system transmit the different AM modulating signal. Then the modulated signals can be combined into a composite signal and transmitted by a higher radio frequency suitable for transmission over a wireless channel. The transmitted signal can be modulated into AM or FM modulation. The KL-93007 module is designed for learning the FDM multiplexer and demultiplexer to know how the signals are processed in FDM system. In this chapter one can understand the signals processed by measuring each channel's signal and how to modulate and demodulate the signals in this module.

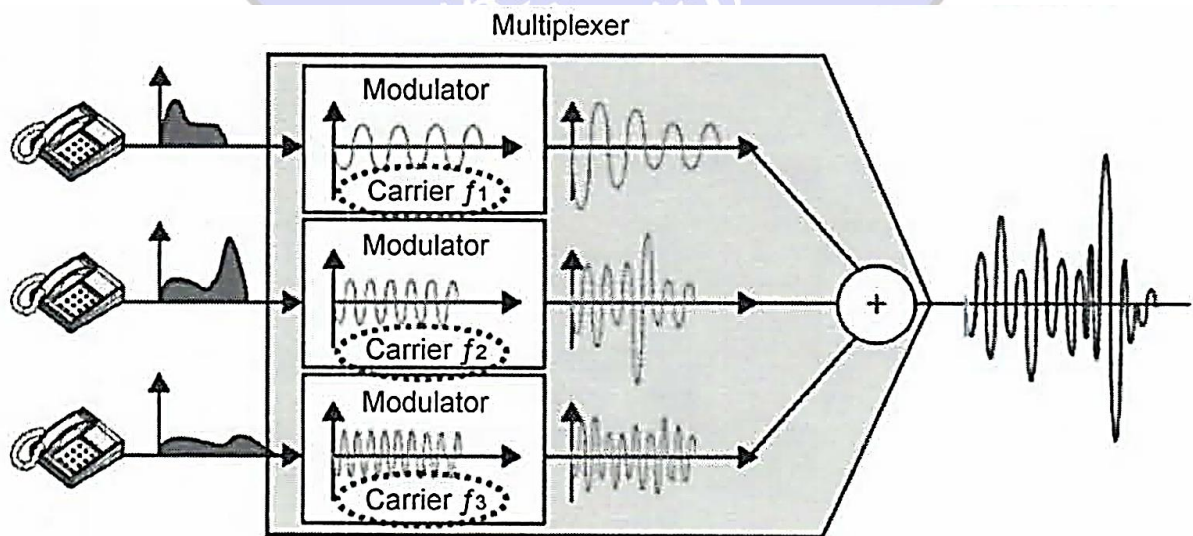
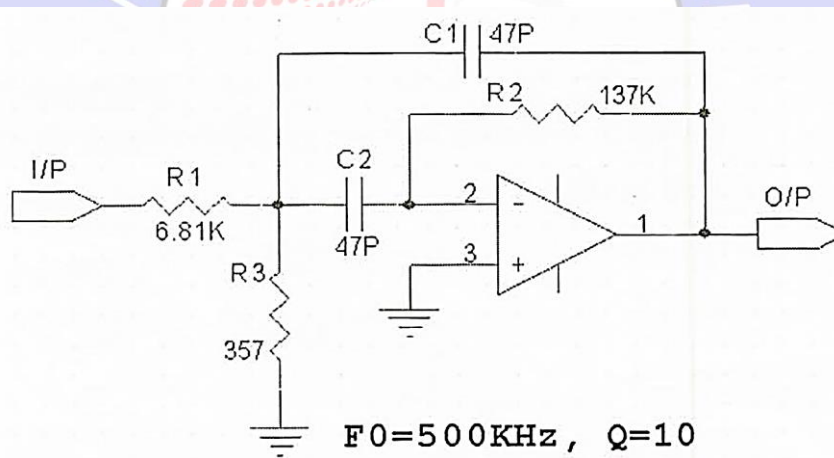

Fig. 21-2 Illustrating the modulating and composite signal in FDM system

### Band-pass filter of FDM demultiplexer

Because the signal is composite, the receiver must separate the specific signal to demodulate and recover. In order to separate the specific signal (AM modulating signal) with specific frequency, the tuner must be used for filtering out the useless data to obtain the correctly AM modulating signal in specific channel. So, the tuner plays the important role in FDM demultiplexer. Tuner is a kind of band-pass filter. Its center frequency can be adjusted by variable resistor. In FDM demultiplexer system the band-pass filters with high quality factor (Q factor) and different center frequency must be used for separating the composite signal in channel. The characteristics of band-pass filter are introduced in this section.

In real application, there are many band-pass filters with high Q factor. For simply, only the single-stage second-order band-pass filter is introduced. The simulations of circuit and frequency response use the TI Filter Design Program. Fig. 21-3(a) shows the single-stage second-order band-pass filters with center frequency 500kHz and Q factor 10. Fig. 21-3(b) shows the single-stage second-order band-pass filters with center frequency 500kHz and Q factor 20. Fig. 21-4 shows the frequency response of single-stage second-order band-pass filters with center frequency 500kHz and Q factor 20.



(a) Q=10 single-stage second-order 500kHz BPF circuit



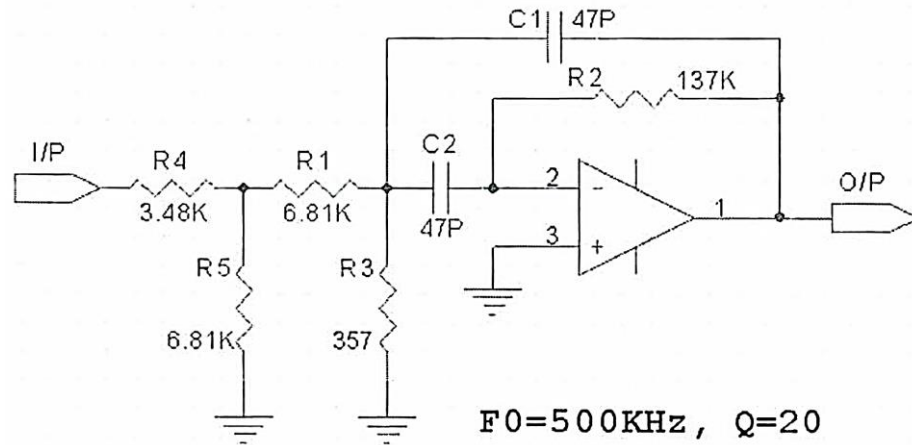

(b)  $Q=20$  single-stage second-order 500kHz BPF circuit

Fig. 21-3

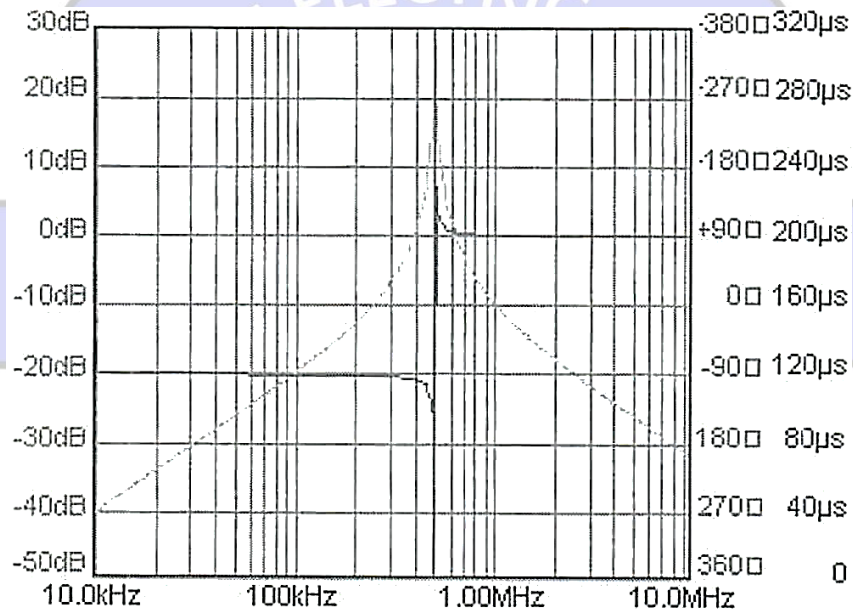

Fig. 21-4  $Q=20$  frequency response of single-stage second-order BPF circuit

The quality factor ( $Q$  factor) can be tuned by variable resistor VR11 (250K) as Fig. 21-5 shows. The circuit and its frequency response are shown in Fig. 21-6 and Fig. 21-7.

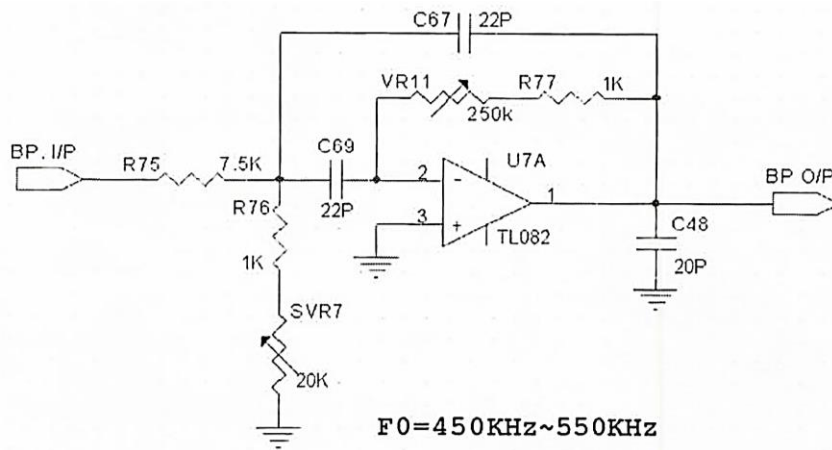
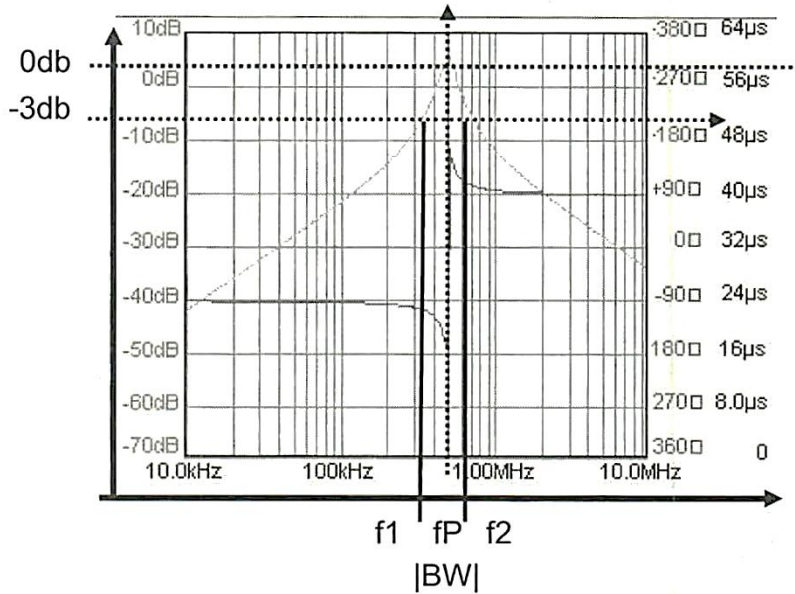

Fig. 21-5 tunable single-stage second-order BPF circuit



$$f_2 - f_1 = BW \quad Q = \frac{f_p}{BW} \quad H(s) = \frac{\omega_p S}{s^2 + \left(\frac{\omega_p}{Q_p}\right)s + \omega_p^2}$$

Fig. 21-6 frequency response of BPF and definition of bandwidth, Q factor transform function

The circuit of typical single-stage second-order BPF is shown in Fig. 21-7 and its transfer function is  $H(s)$

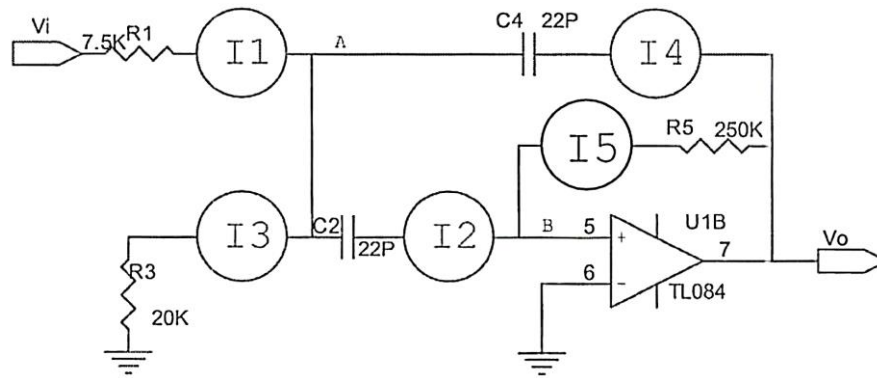

Fig. 21-7 typical single-stage second-order BPF circuit

$$H(s)(BPF) = \frac{-s\left(\frac{1}{R_1 C_4}\right)}{s^2 + s\left[\frac{C_2 + C_4}{R_5 C_2 C_4}\right] + \left(\frac{1}{R_1} + \frac{1}{R_3}\right) / R_5 C_2 C_4}$$

$$\omega_p = \frac{1}{R_1 C_4} \quad \omega_p^2 = \left(\frac{1}{R_1} + \frac{1}{R_3}\right) / R_5 C_2 C_4 = \frac{1}{(R_1 // R_3) R_5 C_2 C_4}$$

$$\frac{\omega_p}{Q} = (C_2 + C_4) / R_5 C_2 C_4$$

If  $f = f_p$ , the magnitude is

$$|H(jf_p)| = G = \frac{\frac{1}{R_1 C_4}}{(C_2 + C_4) / R_5 C_2 C_4} = \frac{R_5}{R_1 \left[1 + \frac{C_4}{C_2}\right]}$$

The  $\omega_p$ ,  $\omega_p^2$  and  $\frac{\omega_p}{Q}$  can derive R1, R3 and R5 respectively. The relationships are

$$R_1 = \frac{Q_p}{GC_4 \omega_p} \quad R_3 = \frac{Q_p}{(2Q_p^2 - G)C_4 \omega_p} \quad R_5 = \frac{2Q_p}{C_4 \omega_p}$$

If  $C_2 = C_4 = C$ , then  $G = \frac{R_5}{2R_1}$ , that is  $R_5 = 2GR_1$ . The following results can be obtained.

$$R_1 = \frac{Q_p}{2\pi f_p GC} \quad R_3 = \frac{Q_p}{2\pi f_p C(2Q_p^2 - G)} \quad R_5 = \frac{Q_p}{\pi f_p C}$$

Using  $\omega_p^2 = \frac{1}{(R_1 // R_3) R_5 C_2 C_4}$ , we can obtain  $f_p = \frac{1}{2\pi C \sqrt{(R_1 // R_3) R_5}}$ .

R3 must be positive, so that  $(2Q_p^2 - G) > 0$ , indicating  $2Q_p^2 > G$  that is  $Q_p > \sqrt{\frac{G}{2}}$ .

Because the phase shift between the input and output signal in BPF, increasing Q factor could cause the phenomenon of oscillation. It must be adjusted carefully. The Q factor can be

increased by connecting two single-stage second-order BPFs that is two-stage fourth-order BPF. The circuit structure is shown in Fig.21-8 & its frequency response is shown in Fig.21-9.

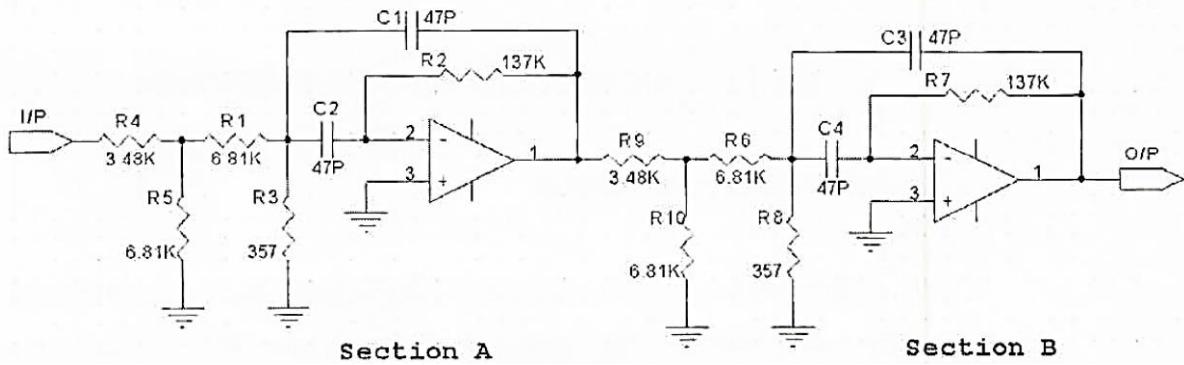

Fig. 21-8 two-stage four-order BPF circuit

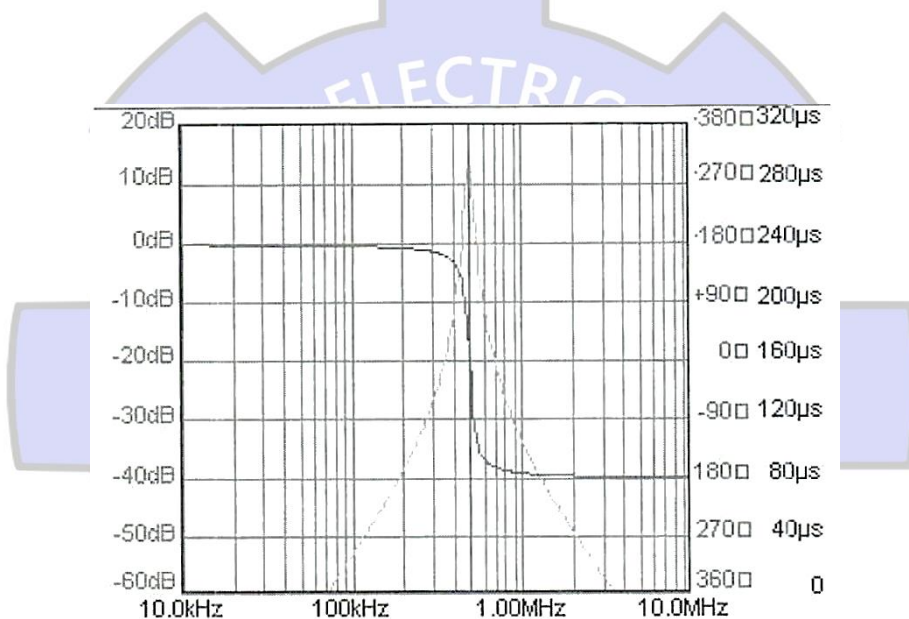

Fig. 21-9 frequency response of two-stage four-order BPF circuit

The two-stage four-order BPF is utilized in KL-93007 module. The circuit is shown in Fig. 21-10 and its experimental processes are shown below.

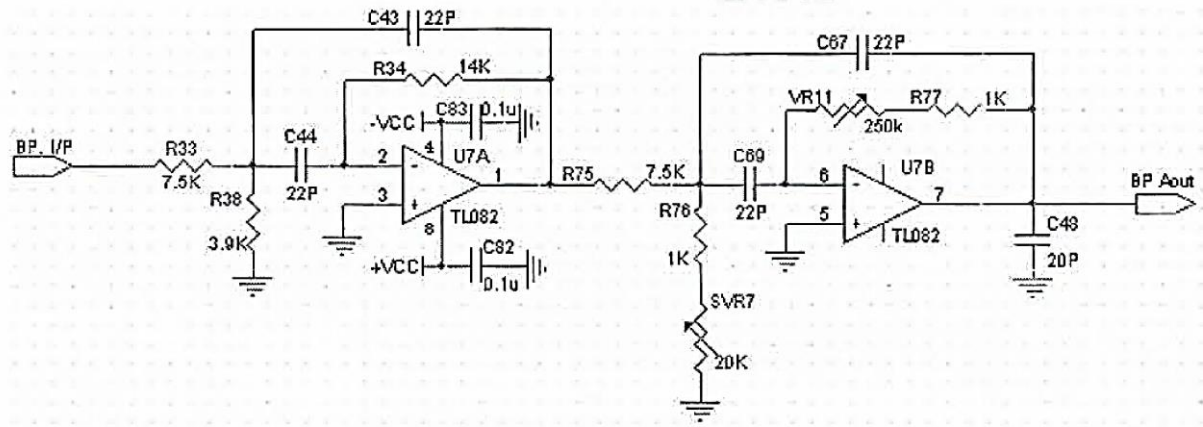
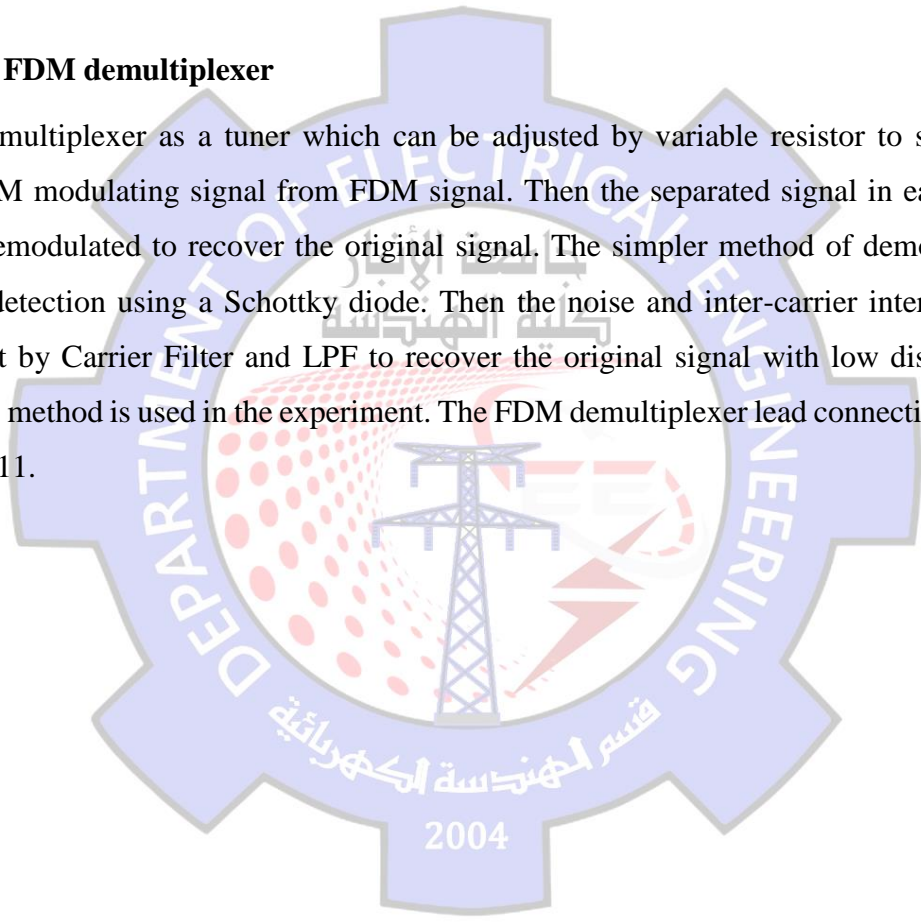

Fig. 21-10 two-stage four-order tunable BPF circuit

### 3-channel FDM demultiplexer

BPF in demultiplexer as a tuner which can be adjusted by variable resistor to separate the specific AM modulating signal from FDM signal. Then the separated signal in each channel must be demodulated to recover the original signal. The simpler method of demodulation is envelope detection using a Schottky diode. Then the noise and inter-carrier interference are filtered out by Carrier Filter and LPF to recover the original signal with low distortion and noise. This method is used in the experiment. The FDM demultiplexer lead connecting is shown in Fig. 21-11.



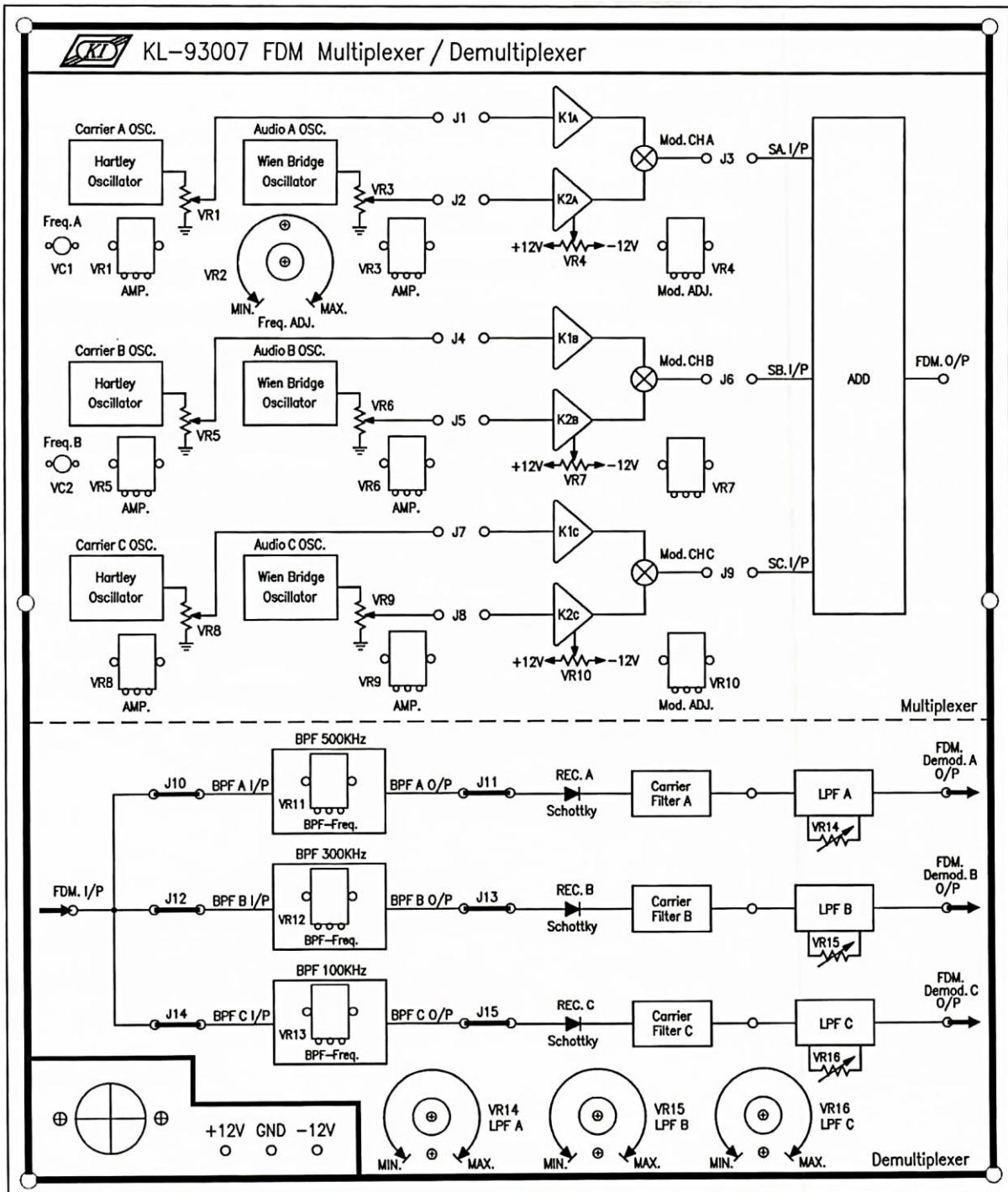

Fig. 21-11 FDM demultiplexer lead connecting diagram

**Experiment 21-1 FDM multiplexer experiment**

The experimental module is 3-channel FDM multiplexer, the module diagram is shown in Fig. 21-12. The Wien Bridge Oscillator is used for audio signal with low frequency and Hartley oscillator is for carrier. The frequency range of Carrier A is 490kHz - 550kHz (adjust VC1) and the output amplitude range is 0-6Vpp continuously adjustable (adjust VR1); the frequency range of Audio A is 1.3kHz - 50kHz (adjust VR2) and the output amplitude range is 0-6Vpp

continuously adjustable (adjust VR3). The frequency range of Carrier B is 290kHz -330kHz (adjust VC2) and the output amplitude range is 0-6Vpp continuously adjustable (adjust VRS); the frequency of Audio B is 3.4kHz and the output amplitude range is 0-6Vpp continuously adjustable (adjust VR6). The frequency of Carrier C is 105kHz and the output amplitude range is 0-6Vpp continuously adjustable (adjust VR8); the frequency of Audio C is 1.0kHz and the output amplitude range is 0-6Vpp continuously adjustable (adjust VR9).

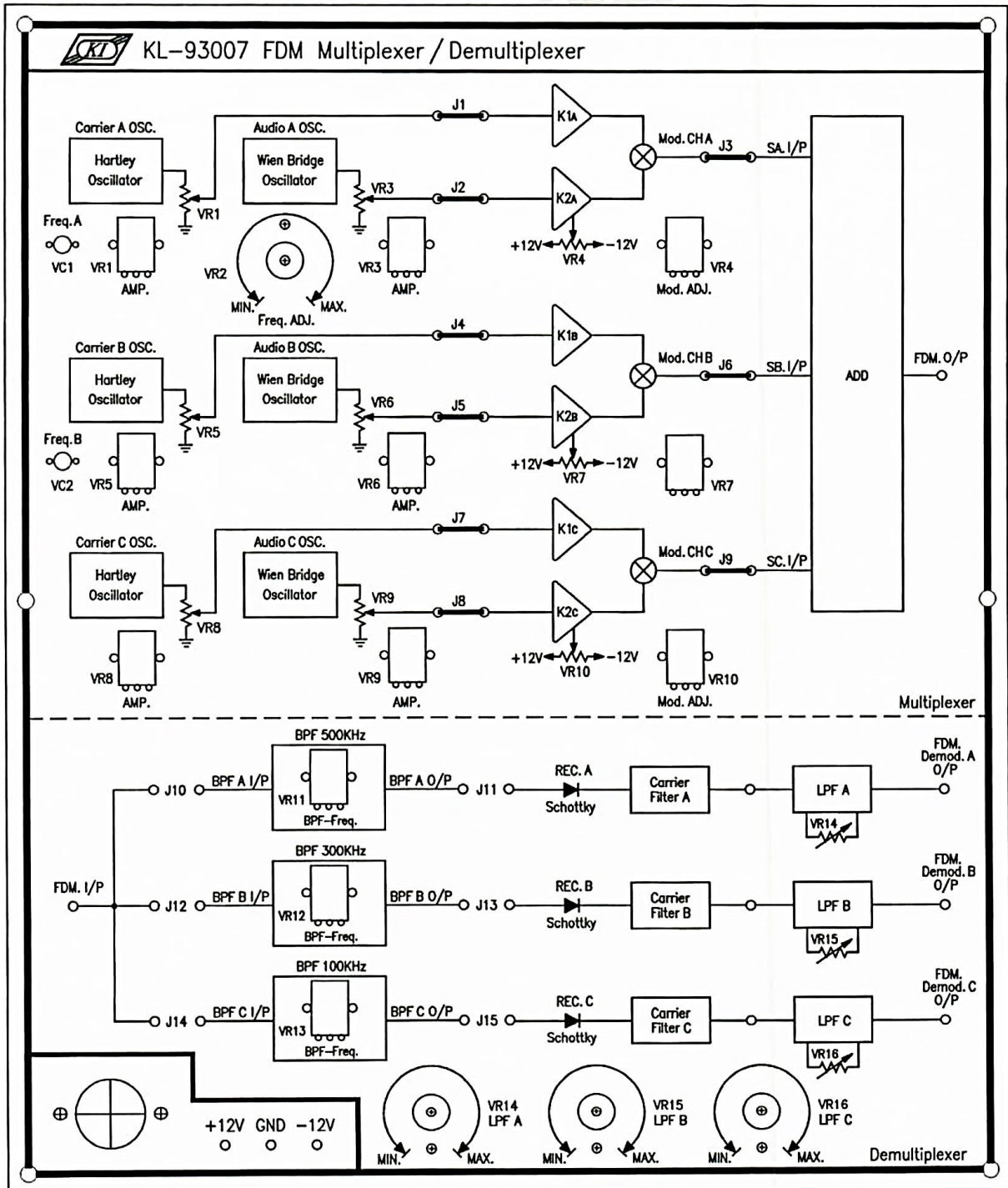

Fig. 21-12 KL-93007 3-channel FDM multiplexer module

The three channels transmit the different AM modulating signal that the audio in each channel is modulated by specific frequency. Then the three modulated signals are combined into a composite signal. In general, the composite signal must be modulated by higher radio frequency for wireless transmission. The RF in wireless communication has been introduced in another chapter. For simply introduction, this chapter only introduces the operation of FDM system. The experimental procedures are shown below.

- (1) The frequencies of modulating in 3-channel FDM are set at 500kHz, 300kHz and 100kHz respectively and audio are set at 5kHz, 3.4kHz and 1kHz respectively. The reference waveforms are shown in Fig. 21-13.

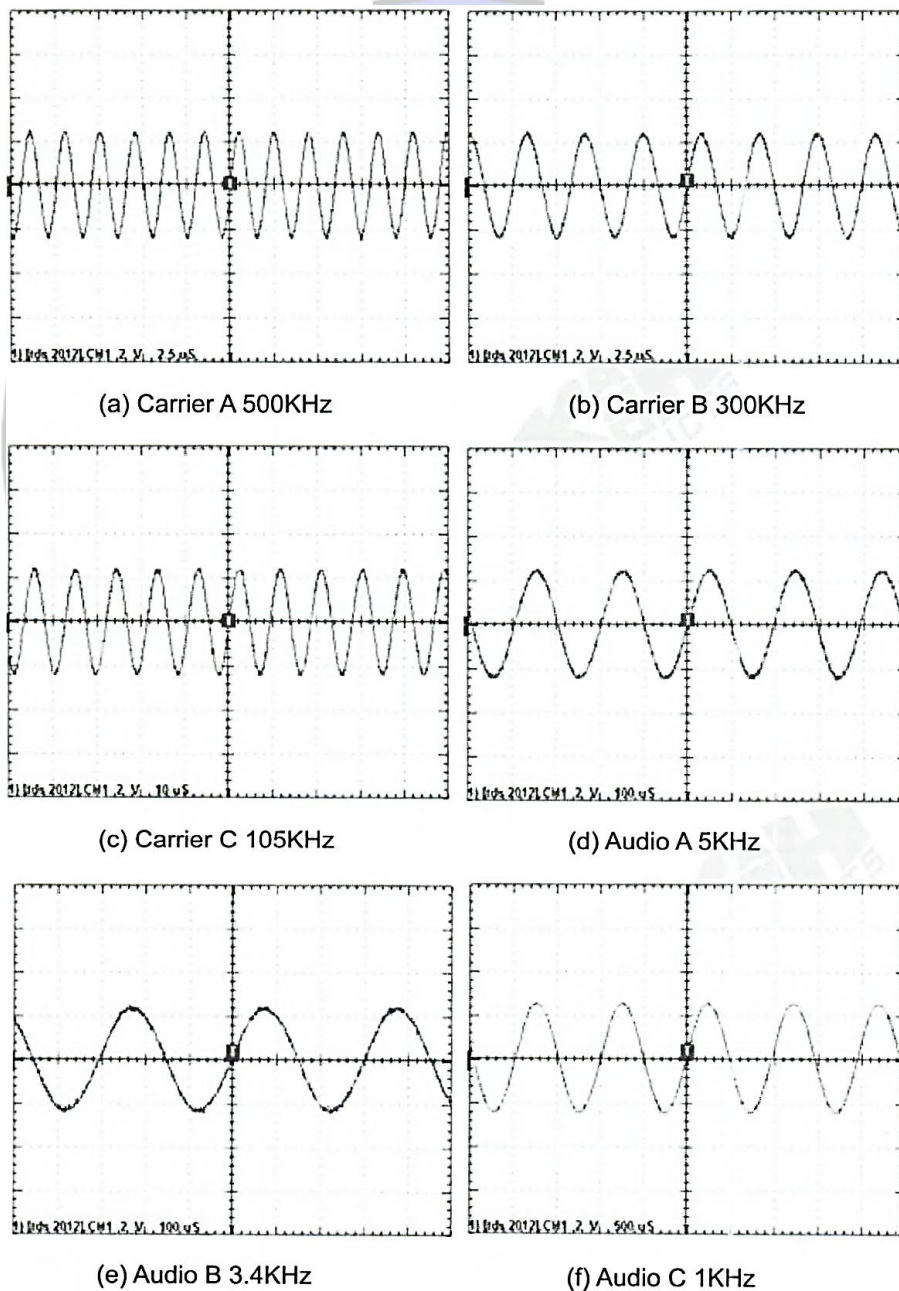
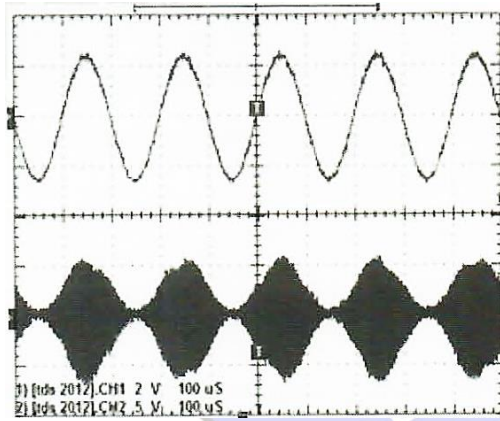

Fig. 21-13



- (2) Adjust the Mod.ADJ VR4, VR7 and VR10 respectively to modulate audio and carrier as Fig. 21-14 shows. Fig. 21-14(a) shows the audio A 5kHz and the its AM modulation signal modulated with carrier A 500kHz. Fig. 21-14 (b) shows the audio B 3.4kHz and its modulated signal with carrier B 300kHz. Fig. 21-14 (c) shows the audio C 1kHz and its modulated signal with carrier C 105kHz.



(CH1 Frequency 5.17kHz CH1: Vpp 5.04V)

(CH2 Frequency 501.5kHz CH2: Vpp 12.6V)

(a) Audio A 5kHz and AM modulation with carrier A 500kHz

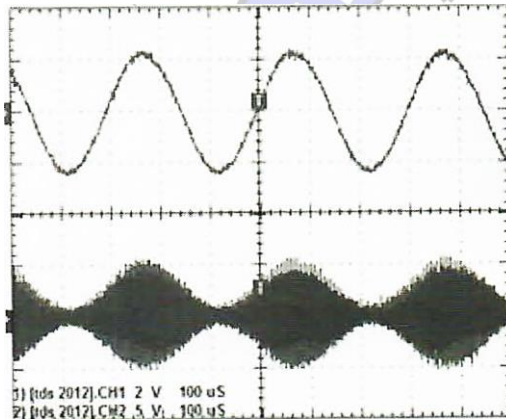

(CH1 Frequency 3.356kHz CH1 Vpp 5.12V)

(CH2 Frequency 296.1kHz CH2 Vpp 11.6V)

(b) Audio B 3.4kHz and AM modulation with carrier B 300kHz

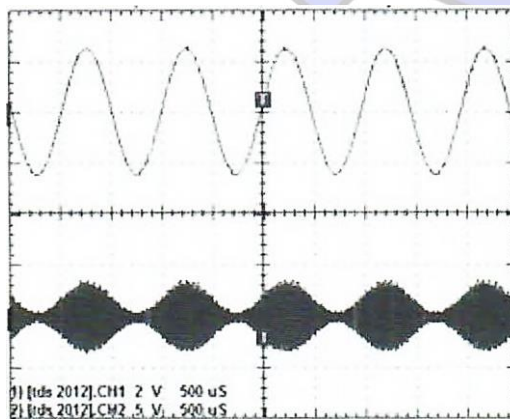

(CH1 Frequency 1.022kHz CH1 Vpp 5.20V)

(CH2 Frequency 110.3kHz CH2 Vpp 8.20V)

(c) Audio C 1KHz and AM modulation with carrier C 105kHz

Fig. 21-14

- (3) After modulating, the three modulated signals with different frequency are combined into a composite signal by the ADD of FDM multiplexer. The FDM multiplexer output FDM.O/P and its spectrum are shown in Fig. 21-15.

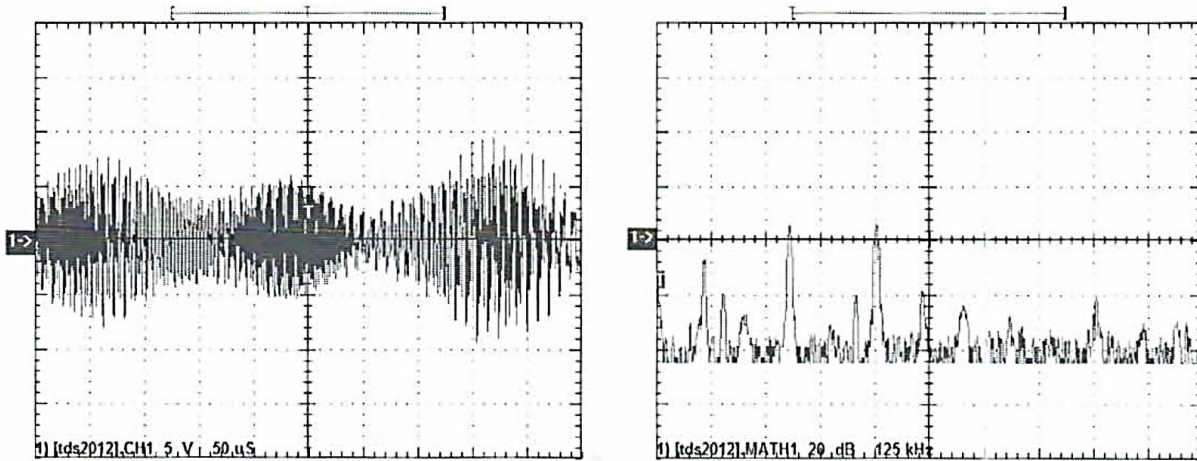

Fig. 21-15 FDM.O/P output waveform and its spectrum

- (4) Adjust respectively the Carriers and Audios in each channel as Table 21-1 shows. Record and analyze each AM modulating signal and FDM.O/P signal in Table 21-1

Table 21-1 AM modulation of 3-channel FDM multiplexer and FDM.O/P signal

Input signal	Measurement	Waveform
<p>Channel A AM modulation ratio 70% Carrier A: 530kHz, 5Vpp Audio A: 5kHz, 5Vpp</p> <p>Channel B AM modulation ratio 80% Carrier B: 310kHz, 5Vpp Audio B: 3.4kHz, 5Vpp</p> <p>Channel C AM modulation ratio 70% Carrier C: 105kHz, 5Vpp Audio C: 1kHz, 5Vpp</p>	AM modulation (Mod.CHA)	
	AM modulation (Mod.CHB)	
	AM modulation (Mod.CHC)	
	FDM.O/P	
	FDM.O/P spectrum	

Input signal	Measurement	Waveform
<p>Channel A AM modulation ratio 70% Carrier A: 490kHz, 5Vpp Audio A: 2kHz, 5Vpp</p> <p>Channel B AM modulation ratio 70% Carrier B: 290kHz, 5Vpp Audio B: 3.4kHz, 5Vpp</p> <p>Channel C AM modulation ratio 90% Carrier C: 105kHz, 5Vpp Audio C: 1kHz, 5Vpp</p>	AM modulation (Mod.CHA)	
	AM modulation (Mod.CHB)	
	AM modulation (Mod.CHC)	
	FDM.O/P	
	FDM.O/P spectrum	

### Experiment 21-2 BPF characteristics of FDM demultiplexer

The carrier frequencies in the three channels of FDM are 500kHz, 300kHz and 100kHz respectively. In order to separate the composite signal from FDM multiplexer, its bandwidth of each channel cannot overlap other neighbor channel to avoid inter-carrier interference. The bandwidths of tuners in this system are 100kHz thus these channels at 500kHz, 300kHz and 100kHz would not be interfered by each other. KL-93007 3-channel FDM demultiplexer module is shown in Fig.21-16. The tuners' characteristics at 500kHz, 300kHz and 100kHz are shown as below.

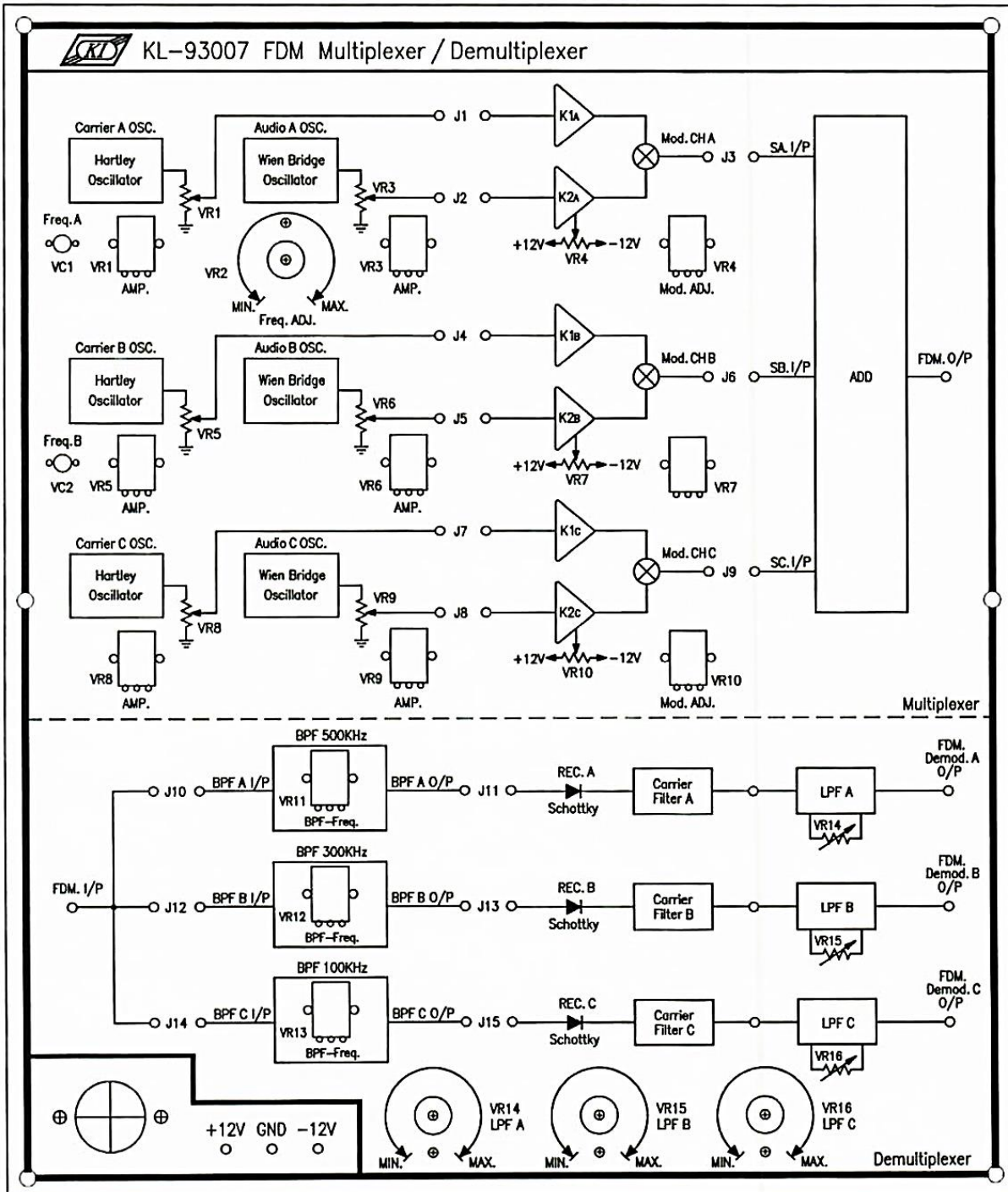

Fig. 21 -16 KL-93007 3-channel FDM demultiplexer module

- (1) The result of frequency responses at different frequencies via 500kHz BPF are shown in Table 21-2. The output waveforms at different input signals, 600kHz, 500kHz, 400kHz and 300kHz, are shown in Fig. 21-17.

Table 21-2 Frequency response of 500kHz BPF at different input frequency

500KHz band-pass filter (BPF A)			
BPF A I/P(Freq.)	Amplitude Vpp	BPF A O/P(Freq.)	Amplitude Vpp
600KHz	3Vpp	600KHz	2.6Vpp
500KHz	3Vpp	500KHz	3.0Vpp
400KHz	3Vpp	400KHz	2.0Vpp
300KHz	3Vpp	300KHz	800mVpp

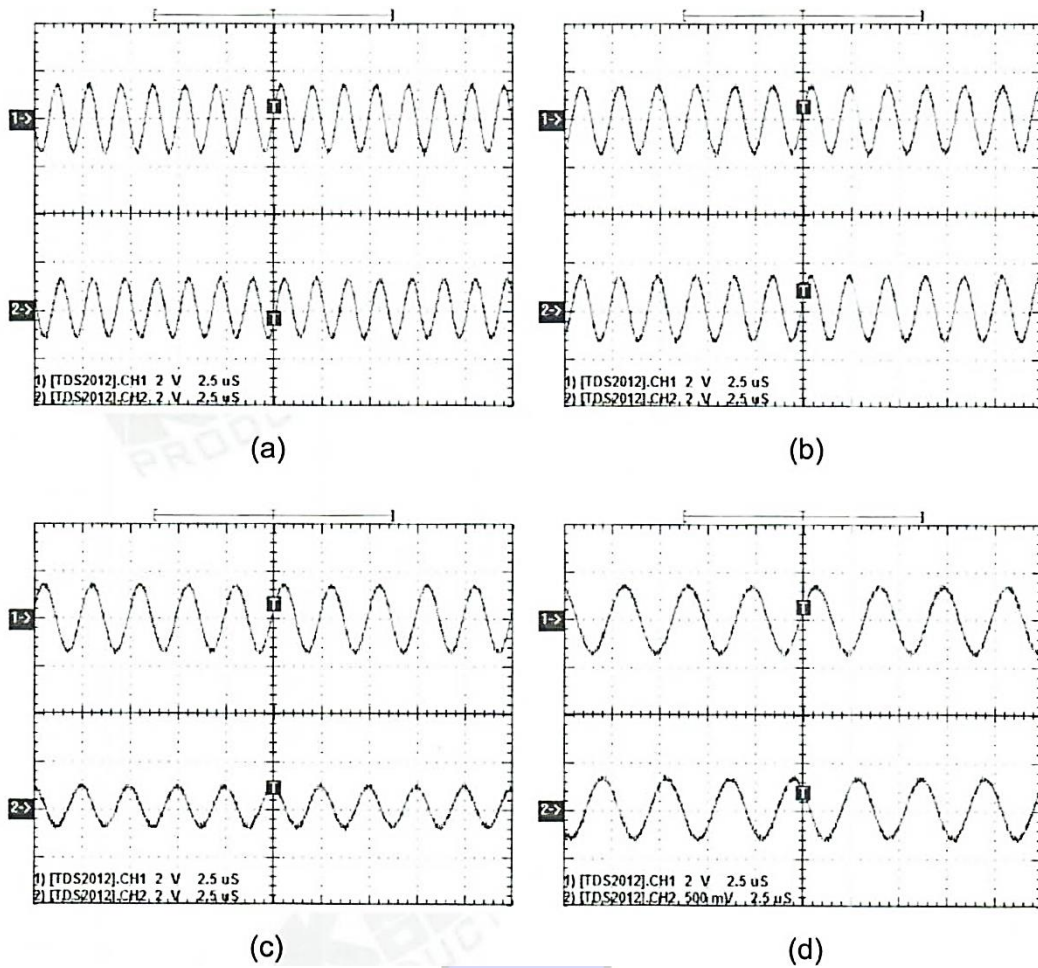

Fig. 21-17 (a)600kHz signal and its frequency response over 500kHz BPF,  
 (b)500kHz signal and its frequency response over 500kHz BPF,  
 (c)400kHz signal and its frequency response over 500kHz BPF,  
 (d)300kHz signal and its frequency response over 500kHz BPF,

- (2) The range of tunable 500kHz BPF is 570kHz – 460kHz. Fig. 21-18 shows the maximum and minimum frequency response by adjusting VR11.

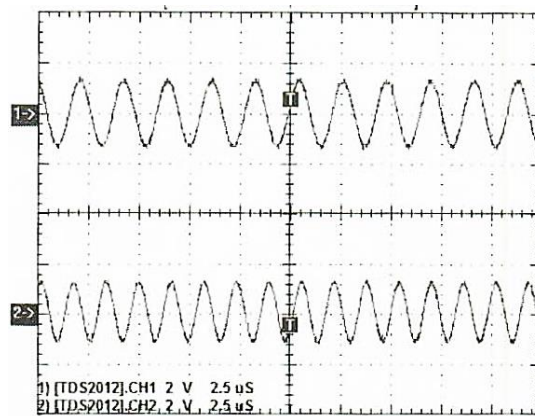

Fig. 21-18 Maximum and minimum frequency response of tunable 500kHz BPF

- (3) The result of frequency responses at different frequencies via 300kHz BPF are shown in Table 21-3. The output waveforms at different input signals, 500kHz, 400kHz, 300kHz, 200kHz and 100kHz, are shown in Fig. 21-19

Table 21-3 Frequency response of 300kHz BPF at different input frequency

300KHz band-pass filter (BPF B)			
BPF B I/P(Freq.)	Amplitude Vpp	BPF B O/P(Freq.)	Amplitude Vpp
500KHz	3Vpp	500KHz	850mVpp
400KHz	3Vpp	400KHz	2.5Vpp
300KHz	3Vpp	300KHz	4.8Vpp
200KHz	3Vpp	200KHz	1.3Vpp
100KHz	3Vpp	100KHz	120mVpp

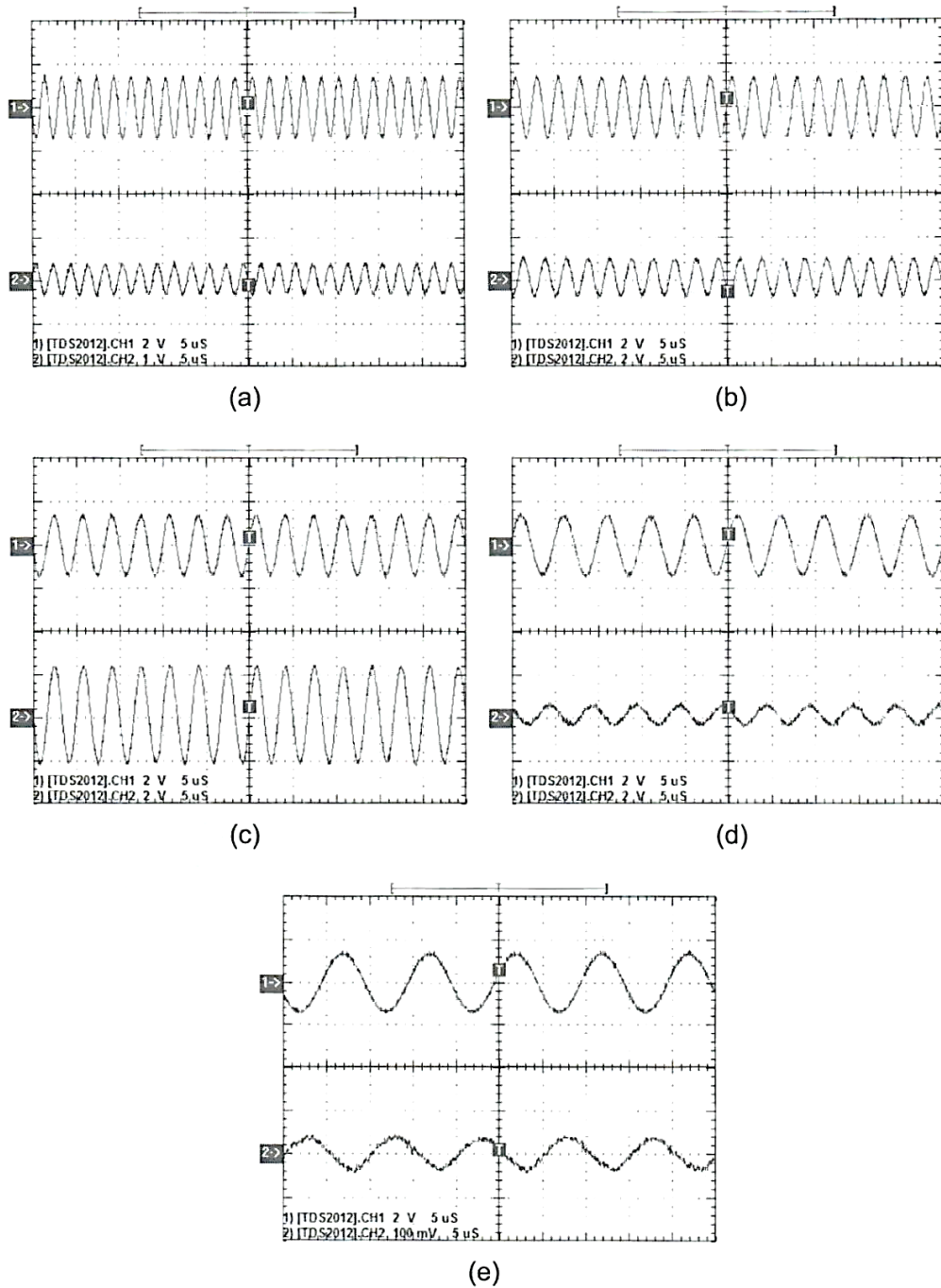

Fig. 21-19 (a) 500kHz signal and its frequency response over 300kHz BPF  
(b) 400kHz signal and its frequency response over 300kHz BPF  
(c) 300kHz signal and its frequency response over 300kHz BPF  
(d) 200kHz signal and its frequency response over 300kHz BPF  
(e) 100kHz signal and its frequency response over 300kHz BPF

- (4) The range of tunable 300kHz BPF is 340kHz-270kHz. Fig. 21-20 shows the maximum and minimum frequency response by adjusting VR12.

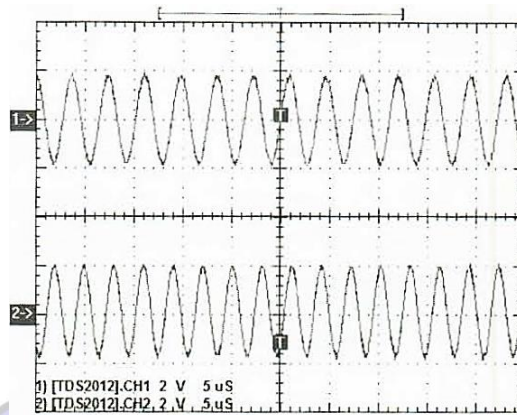

Fig. 21-20 Maximum and minimum frequency response of tunable 300kHz BPF

- (5) The result of frequency responses at different frequencies via 100kHz BPF are shown in Table 21-4. The output waveforms at different input signals, 300kHz, 200kHz, 100kHz, 70kHz and 30kHz, are shown in Fig. 21-21.

Table 21-4 Frequency response of 100kHz BPF at different input frequency

100kHz band-pass filter (BPF C)			
BPF C I/P(Freq.)	Amplitude Vpp	BPF C O/P(Freq.)	Amplitude Vpp
300KHz	3Vpp	300KHz	1.7Vpp
200KHz	3Vpp	200KHz	4Vpp
100KHz	3Vpp	100KHz	13.8Vpp
70KHz	3Vpp	70KHz	6.5Vpp
30KHz	3Vpp	30KHz	950mVpp



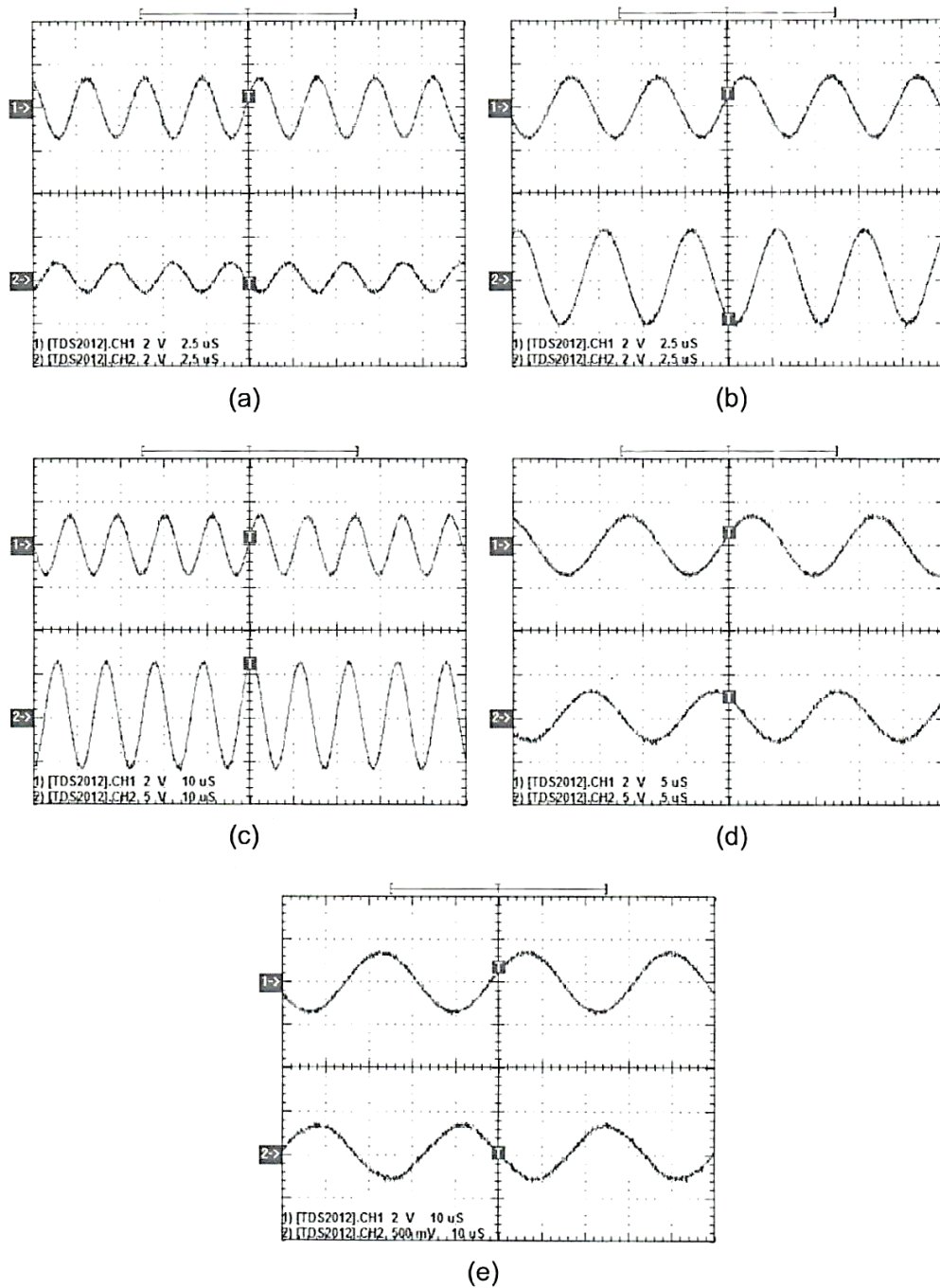

Fig. 21-21 (a) 300kHz signal and its frequency response over 100kHz BPF  
(b) 200kHz signal and its frequency response over 100kHz BPF  
(c) 100kHz signal and its frequency response over 100kHz BPF  
(d) 70kHz signal and its frequency response over 100kHz BPF  
(e) 30kHz signal and its frequency response over 100kHz BPF

- (6) The range of tunable 100kHz BPF is 150kHz-85kHz. Fig. 21-22 shows the maximum and minimum frequency response by adjusting VR13.

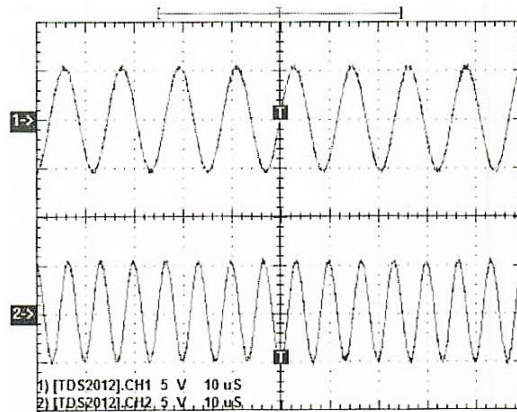

Fig. 21-22 Maximum and minimum frequency response of tunable 100kHz BPF

- (7) As the input signal in Table 21-5, adjust the center frequency and amplitude of BPF respectively. Record and analyze the input and output waveforms in Table 21-5.

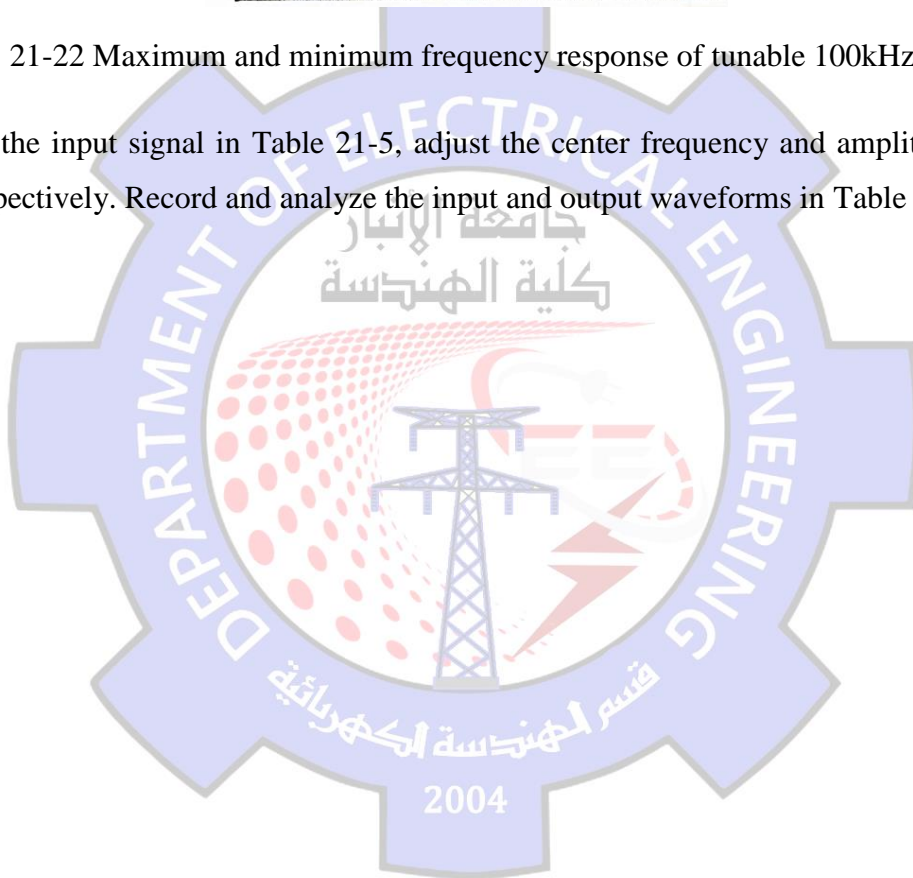
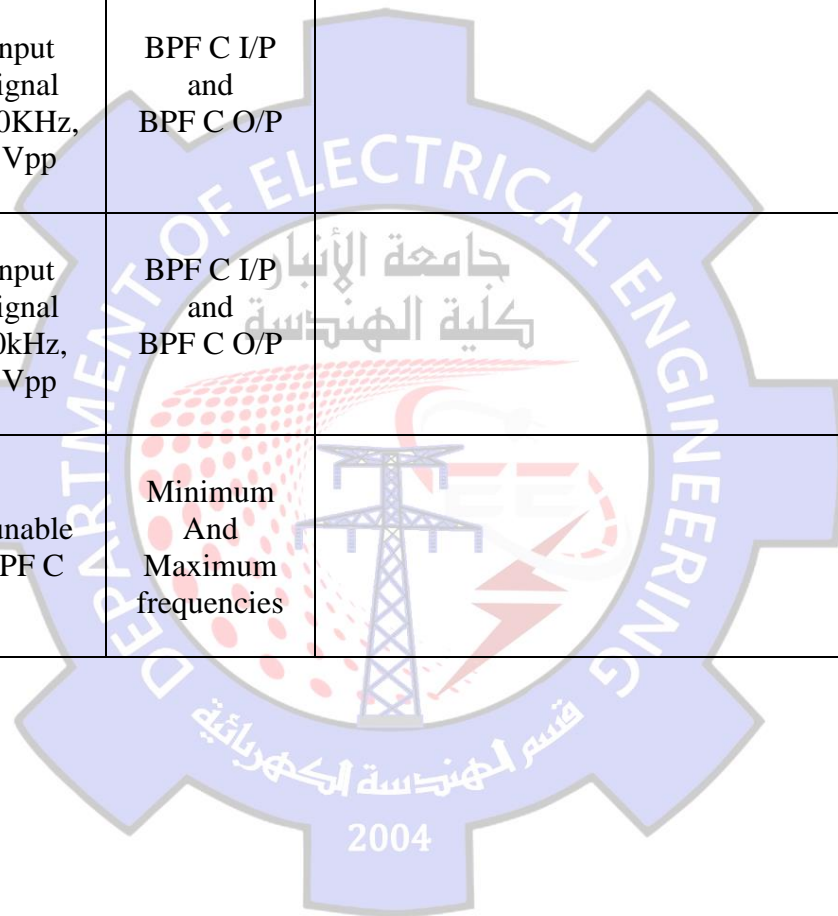

Table 21-5 Frequency response at different frequencies via BPFs

Input signal	Measurement	Waveform
Input signal 600kHz, 3Vpp	BPF A I/P and BPF A O/P	
Input signal 500kHz, 3Vpp	BPF A I/P and BPF A O/P	
Input signal 400kHz, 3Vpp	BPF A I/P and BPF A O/P	
BPF A 500kHz Input signal 300kHz, 3Vpp	BPF A I/P and BPF A O/P	
Input signal 200kHz, 3Vpp	BPF A I/P and BPF A O/P	
Input signal 100kHz, 3Vpp	BPF A I/P and BPF A O/P	
Tunable BPF A	Minimum And Maximum frequencies	

Input signal		Measurement	Waveform
BPF B 300kHz	Input signal 500kHz, 3Vpp	BPF B I/P and BPF B O/P	
	Input signal 400kHz, 3Vpp	BPF B I/P and BPF B O/P	
	Input signal 300kHz, 3Vpp	BPF B I/P and BPF B O/P	
	Input signal 200kHz, 3Vpp	BPF B I/P and BPF B O/P	
	Input signal 100kHz, 3Vpp	BPF B I/P and BPF B O/P	
	Tunable BPF B	Minimum And Maximum frequencies	

Input signal		Measurement	Waveform
BPF C 100kHz	Input signal 300kHz, 3Vpp	BPF C I/P and BPF C O/P	
	Input signal 200kHz, 3Vpp	BPF C I/P and BPF C O/P	
	Input signal 100KHz, 3Vpp	BPF C I/P and BPF C O/P	
	Input signal 30kHz, 3Vpp	BPF C I/P and BPF C O/P	
	Tunable BPF C	Minimum And Maximum frequencies	



**Experiment 21-3 3-channel FDM demultiplexer experiment**

- Finish the connection as Fig. 21-11 shows. Then connect the FDM.O/P of FDM multiplexer to FDM.I/P of demultiplexer. Adjust Audio A (VR2) at 5kHz and carrier A at 500kHz (Freq. A) to modulate two signals by adjusting VR4 as Fig. 21-23(a) shows. Adjust BPF A (VR11) with center frequency 500kHz to obtain the optimal AM modulation signal. Thus, the demodulated signal can be measured via envelope detector (Schottky diode) and Carrier Filter A as Fig. 21-23(b) shows. Finally, LPF A can cancel noise and inter-carrier interference. Adjust VR14 of LPF A to recover sinusoidal audio signal 5kHz in channel A. The recovered signal is shown in Fig. 21-24.

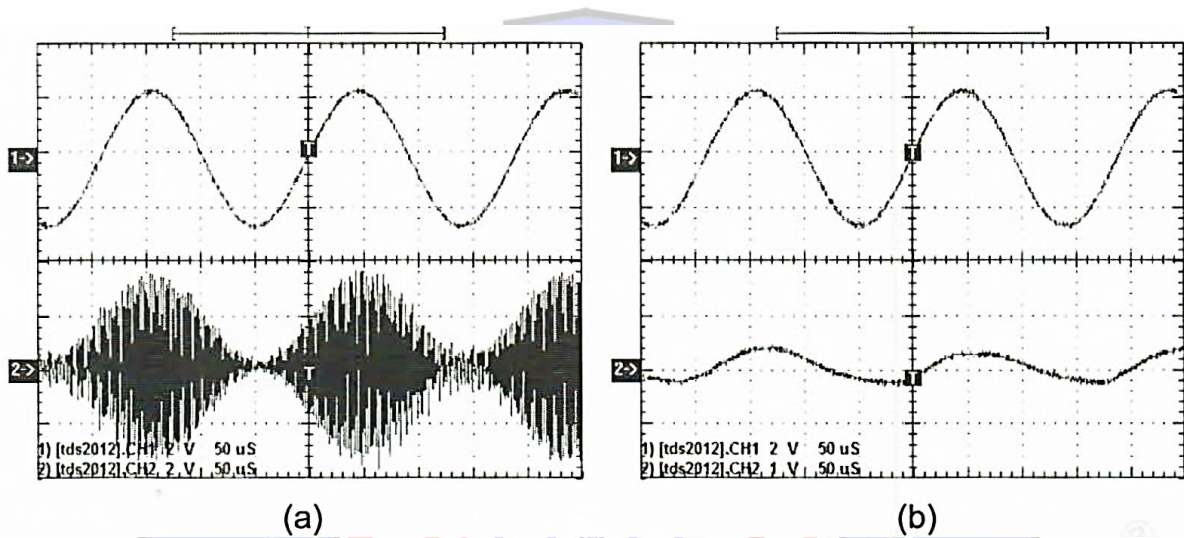

Fig. 21-23 (a) Audio A 5kHz and its AM modulation signal with Carrier A 500kHz via 500kHz BPF. (b) Audio A 5kHz and Carrier Filter A output (modulated signal passes through BPF, envelope detector and Carrier Filter)

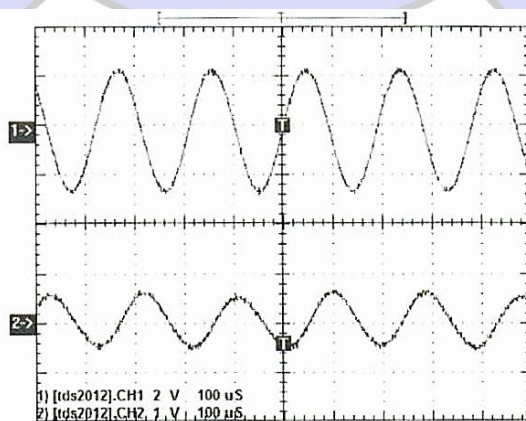

Fig. 21-24 Audio A 5kHz and FDM.Demod.A O/P demodulated signal

- (2) The input frequencies of Audio A and its corresponding demodulated audio signals at 15kHz, 10kHz, 3kHz and 1.5kHz are shown in Fig. 21-25.

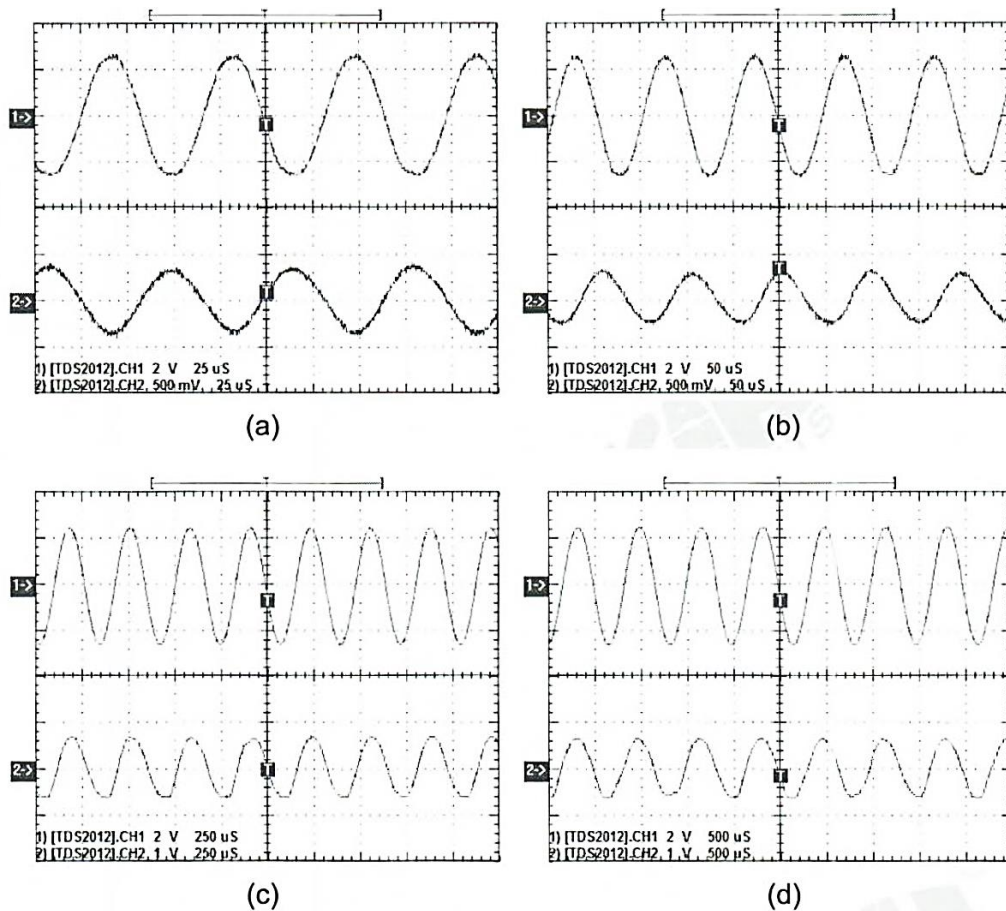

Fig. 21-25 (a) Audio A 15kHz and FDM. Demod.A O/P demodulated signal

(b) Audio A 10kHz and FDM. Demod.A O/P demodulated signal

(c) Audio A 3kHz and FDM. Demod.A O/P demodulated signal

(d) Audio A 1.5kHz and FDM. Demod.A O/P demodulated signal

- (3) The signal of Audio B is set at 3.4kHz. Adjust Carrier B (Freq. B) at 300kHz to modulate two signals by adjusting VR7 as Fig. 21-26(a) shows. Adjust BPF B (VR12) with center frequency 300kHz to obtain the optimal AM modulation signal. Thus, the demodulated signal can be measured via envelope detector and Carrier Filter Bas Fig. 21-26(b) shows. Finally, LPF B can cancel noise and inter-carrier interference. Adjust VR15 of LPF B to recover sinusoidal audio signal 3.4kHz in channel B. The recovered signal is shown in Fig. 21-27.

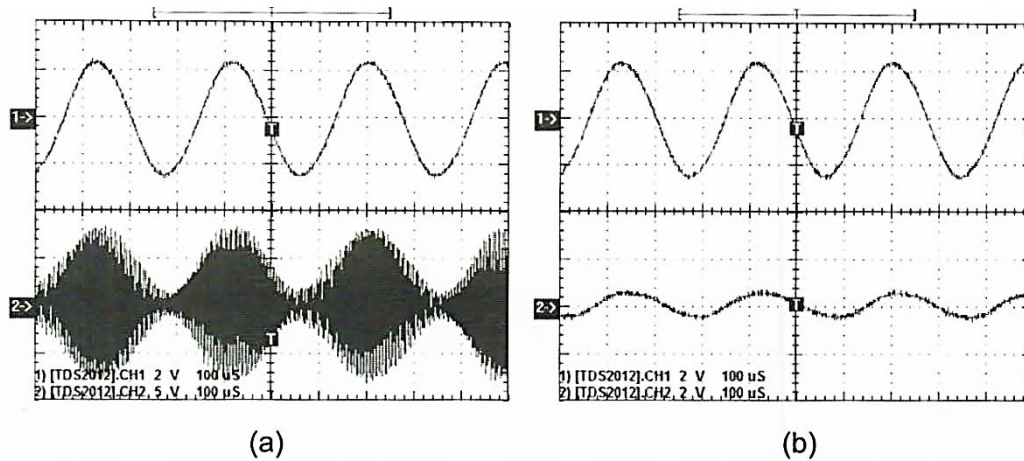

Fig. 21-26 (a) Audio B 3.4kHz and its AM modulation signal with Carrier B 300kHz via 300kHz BPF, (b) Audio B 3.4kHz and Carrier Filter B output (modulated signal passes through BPF, envelope detector and Carrier Filter)

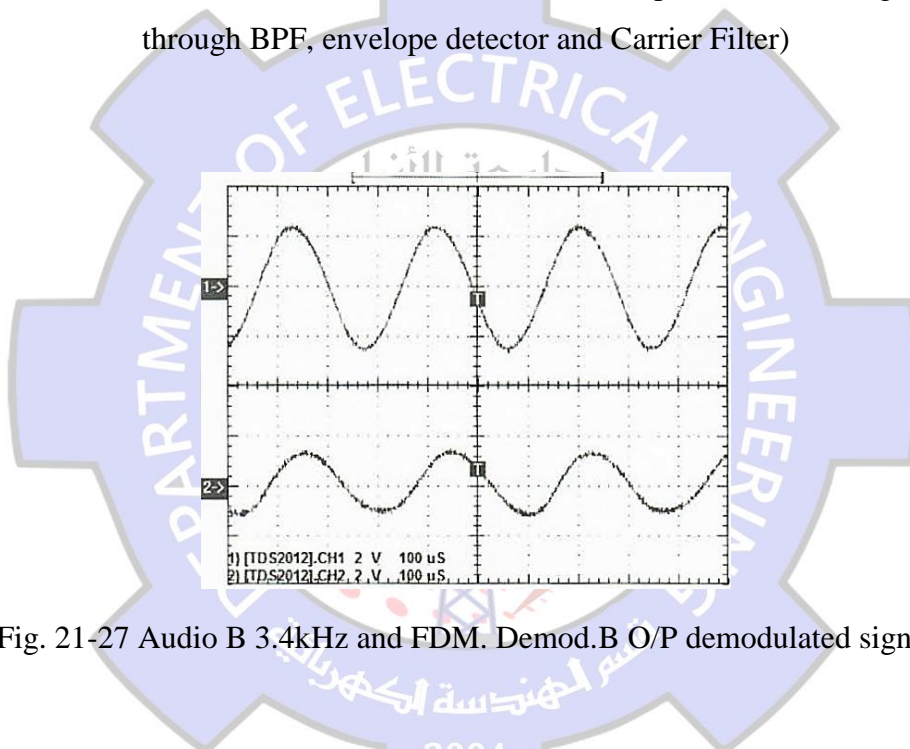

Fig. 21-27 Audio B 3.4kHz and FDM. Demod.B O/P demodulated signal

- (4) The signal of Audio C and Carrier C are set respectively at 1kHz and 100kHz. Adjust VR10 to modulate two signals as Fig. 21-28 shows. Adjust BPF C (VR13) with center frequency 100kHz to obtain the optimal AM modulation signal. Thus, the demodulated signal can be measured via envelope detector and Carrier Filter C as Fig. 21-28(b) shows. Finally, LPF C can cancel noise and inter-carrier interference. Adjust VR16 of LPF C to recover sinusoidal audio signal 1kHz in channel C. The recovered signal is shown in Fig. 21-29.



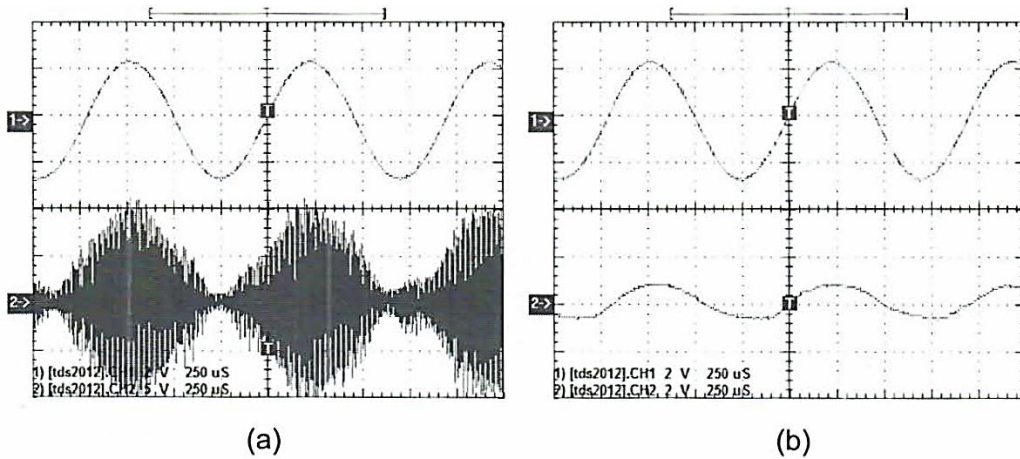

Fig. 21-28 (a) Audio C 1kHz and its AM modulation signal with Carrier C 100kHz via 100kHz BPF , (b) Audio C 1kHz and Carrier Filter C output (modulated signal passes through BPF, envelope detector and Carrier Filter)

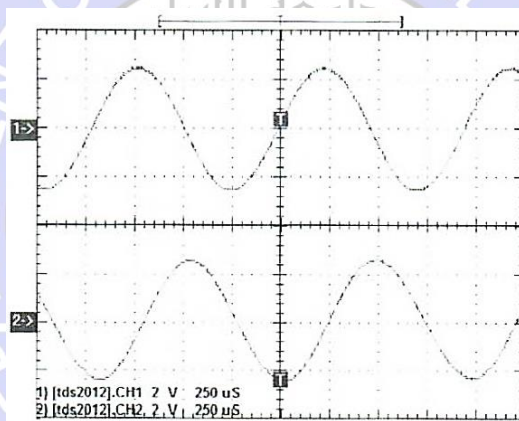
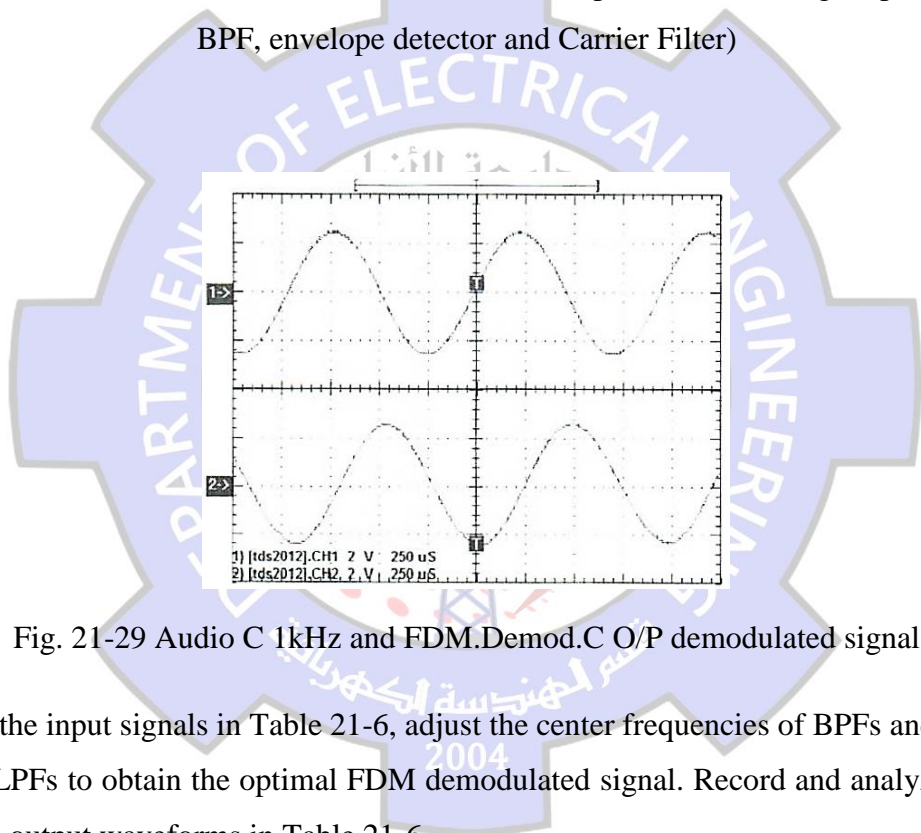

Fig. 21-29 Audio C 1kHz and FDM.Demod.C O/P demodulated signal

- (5) As the input signals in Table 21-6, adjust the center frequencies of BPFs and amplitude of LPFs to obtain the optimal FDM demodulated signal. Record and analyze the input and output waveforms in Table 21-6.

Table 21-6 3-channel FDM input and output waveforms

Input signal	Measurement	Waveform
Channel A  Carrier A: 500kHz, 5Vpp Audio A: 15kHz, 5Vpp	FDM.O/P	
	BPF A O/P	
	Carrier Filter A Output	
	FDM.Demod.A O/P	

Input signal	Measurement	Waveform
Channel A  Carrier A: 500kHz, 5Vpp Audio A: 5kHz, 5Vpp	FDM.O/P	
	BPF A O/P	
	Carrier Filter A Output	
	FDM.Demod.A O/P	

Input signal	Measurement	Waveform
Channel A  Carrier A: 500kHz, 5Vpp Audio A: 1.5kHz, 5Vpp	FDM.O/P	
	BPF A O/P	
	Carrier Filter A Output	
	FDM.Demod.A O/P	

Input signal	Measurement	Waveform
Channel B  Carrier B: 300kHz, 5Vpp Audio B: 3.4kHz, 5Vpp	FDM.O/P	
	BPF A O/P	
	Carrier Filter B Output	
	FDM.Demod.A O/P	

Input signal	Measurement	Waveform
Channel C  Carrier C: 105kHz, 5Vpp Audio C: 1kHz, 5Vpp	FDM.O/P	
	BPF A O/P	
	Carrier Filter C Output	
	FDM.Demod.A O/P	

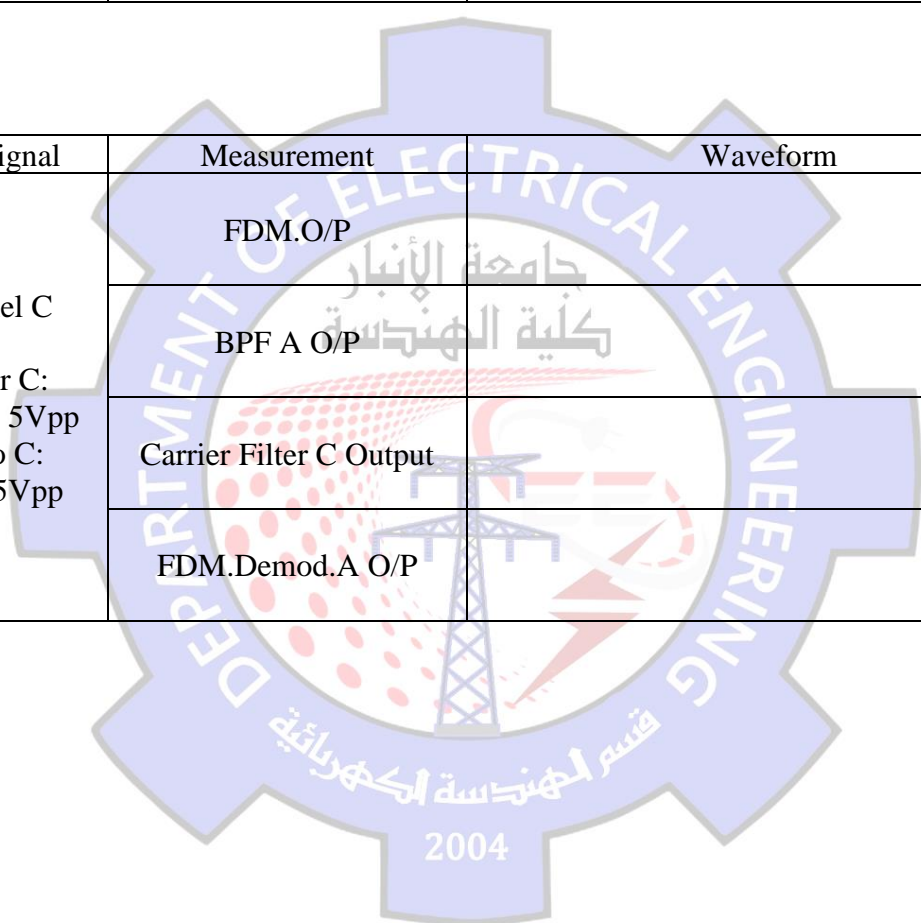

## SPECTRUM OF SIGNALS AND FILTERING

### 1. OBJECTIVES

Use Matlab to study and understand the visualization of the spectrum of a signal in frequency domain. Also, the relation between the audio quality versus the signal bandwidth.

### 2. BANDWIDTH OF A SQUARE PULSE

A square pulse can be represented using the Fourier series as:

$$x(t) = \frac{4}{\pi} \left\{ \sin t + \frac{1}{3} \sin 3t + \frac{1}{5} \sin 5t + \dots + \frac{1}{2n-1} \sin(2n-1)t \right\}$$

This can be drawn according to the selected  $n$  as

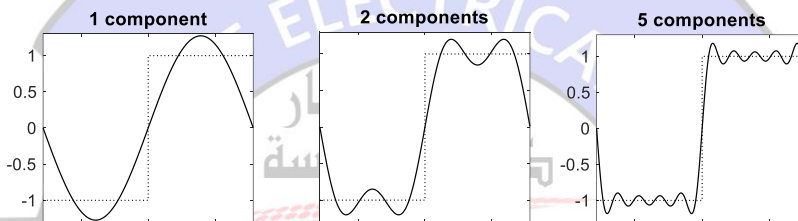

- (1) Run the following code.
- (2) Examine different values for  $n$ .
- (3) For each selection in the above, print the generated plots indicating their values and discuss these cases.

```
n = 2; % choose a value for n between 1 and 100

t = -pi:.01:pi;
S = zeros(1,length(t));
for p=1:n
    pp = 2*p-1;
    S = S + sin(pp*t)/pp;
end

subplot(2,1,1)
plot(t, S, '-b', 'LineWidth',1);
title(sprintf('Time Domain (%d components)',n));
grid off;hold on;axis([-pi,pi,-1.5,1.5])
stairs([min(t),0,max(t)],pi/4*[-1,1,1], '-.m', 'LineWidth',1);
hold off

subplot(2,1,2)
F = abs(fft(S));
F = F(2:2:2*n);
stem(1:2:2*n,F, '^b', 'LineWidth',1)
axis([0,70,0,max(F)])
title('Frequency Domain');
```

### 3. BANDWIDTH OF AUDIO SIGNALS

- (1) Run the following code using the accompanied audio files.
- (2) Examine different values for the normalized  $F_k$ .
- (3) For each selection in the above, print the generated plots indicating their values and discuss these cases.

```
% choose a value for Fk between 0.01 and 0.99
Fk = .05; % normalized cutoff freq

% Define the filter
[B,A] = butter(4,Fk);
low_pass_filter = @(S) filter(B,A,S);

% load the files
s1 = audioread('file1.wav');
s2 = audioread('file2.wav');
s3 = audioread('file3.wav');
beep = audioread('beep.wav');
playerbeep = audioplayer(beep,44100);

min_L = min([length(s1),length(s2),length(s3)]);

s1 = s1(1:min_L);
s2 = s2(1:min_L);
s3 = s3(1:min_L);

s1_f = low_pass_filter(s1);
s2_f = low_pass_filter(s2);
s3_f = low_pass_filter(s3);

axx = [0,min_L/2,0,20000];

subplot(3,2,1);
semilogy(abs(fft(s1)));
title('Spectrum signal 1');
axis(axx);grid on;

player = audioplayer(s1,44100);
playblocking(player);
playblocking(playerbeep);

subplot(3,2,2);
semilogy(abs(fft(s1_f)));
title('Spectrum signal 1 filtered');
axis(axx);grid on;

player = audioplayer(s1_f,44100);
playblocking(player);
playblocking(playerbeep);
```

```
subplot(3,2,3);  
semilogy(abs(fft(s2)));  
title('Spectrum signal 2');  
axis(axx);grid on;  
  
player2 = audioplayer(s2,44100);  
playblocking(player2);  
playblocking(playerbeep);  
  
subplot(3,2,4);  
semilogy(abs(fft(s2_f)));  
title('Spectrum signal 2 filtered');  
axis(axx);grid on;  
  
player2 = audioplayer(s2_f,44100);  
playblocking(player2);  
playblocking(playerbeep);  
  
subplot(3,2,5);  
semilogy(abs(fft(s3)));  
title('Spectrum signal 3');  
axis(axx);grid on;  
  
player3 = audioplayer(s3,44100);  
playblocking(player3);  
playblocking(playerbeep);  
  
subplot(3,2,6);  
semilogy(abs(fft(s3_f)));  
title('Spectrum signal 3 filtered');  
axis(axx);grid on;  
  
player3 = audioplayer(s3_f,44100);  
playblocking(player3);  
playblocking(playerbeep);
```

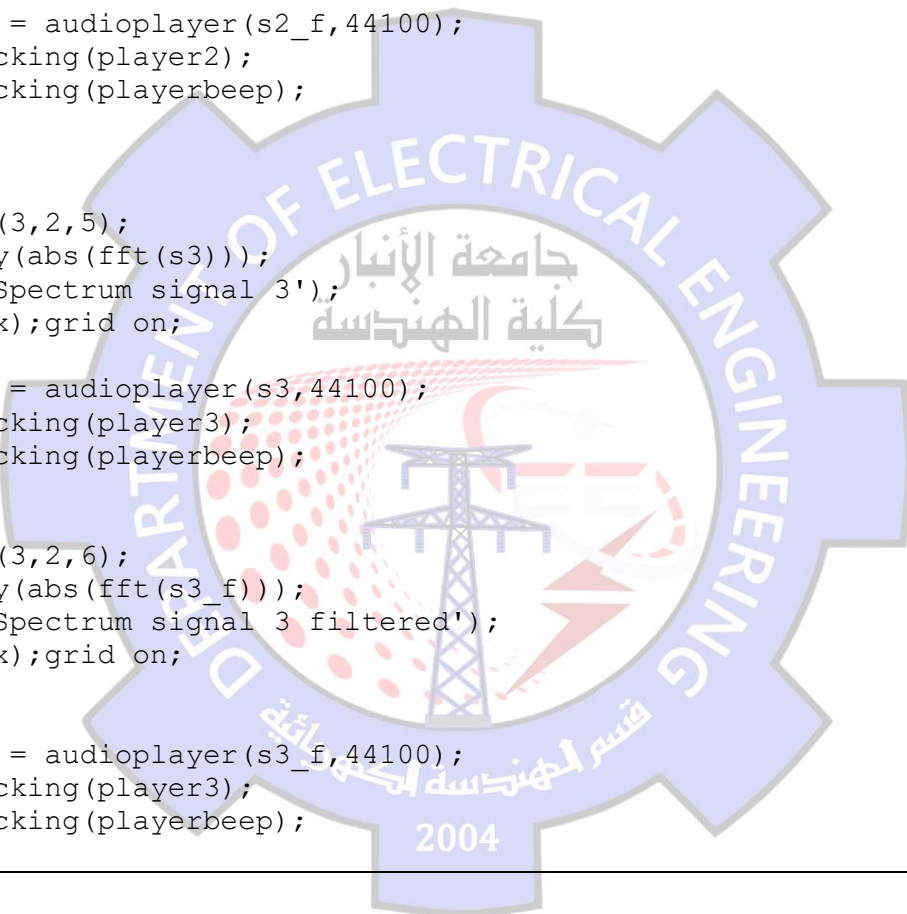

## SIMULATION OF AM & FM

### 4. OBJECTIVES

Use Matlab to study and understand the operation and characteristics of AM and FM.

### 5. AM-DSB-SC

- (4) Run the following code.
- (5) Examine different values for  $A_c$ ,  $A_m$ ,  $\omega_m$ , and  $\omega_c$ .
- (6) For each selection in the above, print the generated plots indicating their values and discuss these cases.

```

wc = 200; Ac = 1.5;
wm = 10;  Am = 1.1;

t = linspace(0,1.5,1000);
m = Am * cos(wm*t);
c = Ac * cos(wc*t);
AM = m.*c;

subplot(3,1,1); plot(t, m); title('Baseband Signal');
subplot(3,1,2); plot(t, c); title('Carrier Signal');
subplot(3,1,3); plot(t,AM); title('AM DSB-SC');
    
```

### 6. AM-DSB-LC

- (1) Run the following code. Compute  $\mu$ .
- (2) Examine different values for  $A_c$  and  $A_m$ . Choose values for these variables to have the following: (a)  $\mu < 1$ , (b)  $\mu = 1$ , (c)  $\mu > 1$ .
- (3) In all the above cases, print the generated plots indicating their  $\mu$ . Discuss these cases.
- (4) Examine different values for  $\omega_m$  and  $\omega_c$ . print the generated plots indicating their values and discuss these cases.

```

wc = 200; Ac = 1.5;
wm = 10;  Am = 1.1;

t = linspace(0,1.5,1000);
m = Am * cos(wm*t);
c = Ac * cos(wc*t);
AM = (Ac+Am*m) .* c;

subplot(3,1,1); plot(t, m); title('Baseband Signal');
subplot(3,1,2); plot(t, c); title('Carrier Signal');
subplot(3,1,3); plot(t,AM); title('AM DSB-LC');
    
```

## 7. FM

- (1) Run the following code. Compute  $\beta$ .
- (2) Examine different values for  $K_f$ . Choose values for this variable to have the following:
  - (a) large  $\beta$  , (b) intermediate  $\beta$  , (c) small  $\beta$  .
- (3) In all the above cases, print the generated plots indicating their  $\beta$ . Discuss these cases.
- (4) Examine different values for  $A_c$  ,  $A_m$  ,  $\omega_m$  , and  $\omega_c$ . print the generated plots indicating their values and discuss these cases.

```

wc = 200; Ac = 1.5;
wm = 10; Am = 1.1;
Kf = 80; % modulation sensitivity

t = linspace(0,1.5,1000);
m = Am * cos(wm*t);
c = Ac * cos(wc*t);
Beta = Am * Kf / wm;
FM = cos(wc*t+Beta*sin(wm*t));

subplot(3,1,1); plot(t, m); title('Baseband Signal');
subplot(3,1,2); plot(t, c); title('Carrier Signal');
subplot(3,1,3); plot(t, FM); title('FM');
    
```

